WHITE PAPER

ELECTRIC MOTORS IN THE ENERGY TRANSITION

Bruno De Wachter for ECI

August 2018

Document Issue Control Sheet

Document Title:	White paper – Electric Motors in the Energy Transition
Publication No:	Cu0254
Issue:	01
Release:	Public
Content provider(s)	Diego Carvajal (ECI), Hans De Keulenaer (ECI), Stefan Fassbinder (ECI), Fernando Nuño (ECI), Alberto J. Fossa (Copper Alliance), Anibal de Almeida (University of Coimbra), João Fong (University of Coimbra), Alex van den Bossche (University of Ghent), Hugh Falkner (Atkins), Maarten van Werkhoven (TPA Adviseurs) , Nobby Yamanouchi (Qatar University).
Author(s):	Bruno De Wachter
Editorial and language review	Andrew Wilson
Content review:	Diego Carvajal (ECI), Stefan Fassbinder (ECI), Fernando Nuño (ECI), Anibal de Almeida (University of Coimbra), João Fong (University of Coimbra), Michael Björkman (Danfoss), Martin Doppelbauer (ETI), Giuseppe Fabri (University of L'Aquila), Jos Habets (Sitech), Tim Marks (AEMT), Tomas Jezdinsky (TJ Market Research).

Document History

Issue	Date	Purpose
1	August 2018	
2		

Disclaimer

While this publication has been prepared with care, European Copper Institute and other contributors provide no warranty with regards to the content and shall not be liable for any direct, incidental or consequential damages that may result from the use of the information or the data contained.

Reviewer evaluations were given serious consideration by the editor and author in the preparation of the manuscript for publication. Nonetheless, the final responsibility for the content resides with the author(s).

Copyright© European Copper Institute.

Reproduction is authorized providing the material is unabridged and the source is acknowledged.

CONTENTS

List of acronyms.....	4
Summary – Electric motors in the energy transition	6
Preamble – Accelerating the energy transition	7
1. The future is electric	9
Key messages.....	9
The energy transition needs electrification	10
The electrification of transport.....	10
Electrification of private transport	11
Electrification of public and goods transport	19
The electrification of heating and cooling	25
Heat pumps.....	25
Electrification of pneumatic and hydraulic systems.....	31
2. Increasing the energy efficiency of motor systems.....	32
Key messages.....	32
The transition towards increased motor efficiency.....	33
EU regulation for motor energy efficiency.....	36
Extending regulation to other motor categories	36
Enhancing the efficiency level to IE4	37
Increasing the impact through improved implementation	38
Increased impact through the growing number of motors in use.....	39
Going beyond the component approach.....	39
International standards on motor system and extended product efficiency.....	39
Motors and variable speed drives (VSDs).....	40
The extended product approach: motor system + transmission + application	41
EnMS.....	41
Heat pump system efficiency.....	43
3. Electric motors and the flexibility challenge.....	44
Key messages.....	44
The flexibility challenge	45
DR in Europe today.....	45
Motor units offering flexibility	46

Motor applications offering flexibility	47
Motor driven system flexibility in space HVAC.....	48
Motor driven system flexibility in industrial process plants.....	48
Motor driven system flexibility in water management systems	49
Flexibility barriers and policy requirements.....	49
4. Sustainable material use –motors in the circular economy	51
Key messages.....	51
The energy transition and the circular economy	52
Motors in the circular economy.....	53
Motor maintenance and refurbishment	53
The motor bill-of-material.....	53
Copper in the circular economy	54
Aluminium in the circular economy.....	56
Steel in the circular economy.....	56
Rare-earth metals in the circular economy.....	56
Design for recycling	57
5. Policy recommendations and other conclusions	60
Optimising the MEPS for motor systems.....	60
A growing number of motors resulting from electrification	61
Motor systems with flexible energy consumption	61
Motors in the circular economy.....	62
Annex – The estimated market increase in motor systems	63
Increase in the share of electricity consumed by motors.....	63
Increase in the number of motors in use.....	64
References.....	66

LIST OF ACRONYMS

- aFRR – Automatic Frequency Restoration Reserve
- ASHP – Air Source Heat Pump
- BEV – Battery Electric Vehicle
- BRP – Balancing Responsible Party
- COP – Coefficient of Performance
- DfR – Design-for-recycling
- EEI – Energy Efficiency Index
- EnMS – Energy Management System
- EPBD – Energy Performance of Buildings Directive
- EROI – Energy Return on Investment
- ETS – Emission Trading Scheme
- EV – Electric Vehicle
- FCEV – Fuel Cell Electric Vehicle
- FCR – Frequency Containment Reserve
- GHG – Greenhouse Gas
- GSHP – Ground Source Heat Pump
- HVAC – Heating Ventilation Air-conditioning
- HEV – Hybrid Electric Vehicle
- ICE – Internal Combustion Engine
- LSEV – Low Speed Electric Vehicle
- MDU – Motor Driven Unit
- MEPS – Minimum Efficiency Performance Standard
- mFRR – Manual Frequency Restoration Reserve
- nZEB – nearly Zero-Energy Building
- PDCA – Plan-Do-Check-Act
- PDS – Power Drive System
- PEF – Primary Energy Factor
- PHEV – Plug-in-Hybrid Electric Vehicle
- PMSM – Permanent Magnet Synchronous Motor
- PM_{2.5} – Particulate Matter (particles with a diameter of less than 2.5 mm)
- PPA – Power Purchase Agreement
- PV – Photovoltaic
- RES – Renewable Energy System
- ROI – Return on Investment
- SPF – Seasonal Performance Factor

- TCO – Total Cost of Ownership
- VSD – Variable Speed Drive
- VRE – Variable Renewable Energy
- WEEE – Waste Electrical and Electronic Equipment

SUMMARY – ELECTRIC MOTORS IN THE ENERGY TRANSITION

The electrical power sector is the fastest to decarbonise because of the wide variety of carbon-free energy sources that can generate electricity, such as PV, wind and hydro. This means that **electrification can help other sectors decarbonise fast and on a large scale**. The share of electricity in energy end-use is expected to increase from the current 17% [1] to around 60 - 70%. The share of electric motors systems will at the least grow along with this, from the current 9% [2 p. 40] to around 30% of energy end-use. Closer examination reveals that motor system numbers will grow even more strongly, since **they are implicated in two major decarbonisation options involving electrification: electric vehicles (EVs) and heat pumps**. See Chapter 3: *The future is electric*.

Such acute market growth for motor systems means that their energy efficiency is even more crucial. Or to formulate it positively, any minor improvement in motor system efficiency, achieved for example through regulation, would immediately have a major impact due to the huge numbers of motors in use. It is therefore an effective decarbonisation path **to further increase motor system efficiency up to the level of the lowest life-cycle cost**. See Chapter 4: *Increasing the efficiency of motor systems*.

The growing share of grid-connected renewable energy systems, which feature naturally variable output, makes the task of grid operators increasingly complex. Electricity should not only be used efficiently, its consumption should also be shifted as much as possible to moments of abundant production. Some sectors with large numbers of motor systems in use are well-equipped to offer this flexibility. Mechanisms should be put in place **to connect electricity users with grid operators so that such far-reaching consumer engagement can be achieved**. See Chapter 5: *Electric motors and the flexibility challenge*.

The energy transition is only sustainable if material use is taken into account. The expected rise in the number of motors poses the question **whether those motors have the potential to function in a circular economy**. Research & Innovation support for rare-earth-free motor development, as well as concepts such as *Design for Recycling* (DfR) can lead the way. See Chapter 6: *Sustainable material use – Motors in the circular economy*.

PREAMBLE – ACCELERATING THE ENERGY TRANSITION

The transition towards world free of carbon emissions is a defining challenge of this generation. There are cost-effective and durable solutions at hand, but this does not make the task self-evident, given the enormous scale and strict time-frame in which we should make it happen.

20 years have passed already since the Kyoto Protocol, and Europe has made encouraging progress. The major part of the transition, however, is still ahead of us. By 2050, EU carbon emissions should be reduced by 80-95% compared to 1990 levels, according to the Kyoto commitment. The current EU roadmap aims for an 80% carbon emission reduction by that date. This target was set after the COP21 Paris Agreement in December 2015, which also aims to limit temperature rise to well below +2°C compared to pre-industrial levels, and insists that joining parties reduce greenhouse gas (GHG) emissions as soon as possible to achieve this general target.

The European Copper Institute (ECI) supports the upper target of 95% but recognises that the final emission reduction step (from 80% to 95%) is highly ambitious, given that the least complex measures will be the first to be acted upon. In any case, the energy transition must take place at a faster rate if we are to achieve the goals of the Kyoto and Paris Protocols in the agreed timescale.

The scale of the required energy transition is massive and involves almost every sector of the economy. To decarbonise all our homes and buildings in time, a faster-than-usual renovation rate is imperative. Industry poses its own challenges because of the sheer volume of energy and process material use. Electricity production is making the fastest transition and has committed to decarbonise well before 2050, permitting other sectors to decarbonise through electrification. One of them is the transport sector, which probably represents the greatest decarbonisation challenge. Along with electricity, hydrogen produced from renewable energy sources may be a useful alternative energy carrier and storage medium if cost-effective technologies can be developed. Different forms of bioenergy will also be part of the solution if their land-use remains responsible and their energy return on investment (EROI) sufficient.

Defeatism is not an option. To take up the challenge, we need multi-level governance. Citizens, cities, business, industry, regional and national governments, as well as international organizations, should act and co-ordinate their actions with each other. Players such as cities, business and industry have an important role since they can act as the bridge between high-level political ambitions and individual citizens.

All stakeholders should match their decisions against a few basic values:

- **Decarbonisation:** Pursuing solutions that make a sizeable contribution and that are scalable to achieve rapid and significant carbon savings. This requires policy stability, a long-term 2050 perspective, and back-casting to achieve the 2050 energy and climate objectives.
- **Cost-effectiveness:** Seeking cost-effective solutions that compete in the market on merit. Minimum lifecycle costing should guide policy design. All cost-effective measures need to be pursued.
- **Circularity:** Expecting products and systems to be durable, easy to repair and highly recyclable in the transition from a fuel-based to a more capital-intensive energy system.
- **Sector coupling:** Believing in integrated energy systems and using digital solutions. We need a systems approach combining renewables and energy efficiency with energy flexibility.
- **Consumer engagement:** Believing in full access to energy markets, green power purchase agreements (PPAs), guarantees of origin, long-term agreements and peer-to-peer energy transactions.

The European Copper Institute (ECI) has made decarbonisation one of its top priorities and calls for an ambitious but pragmatic approach. In 2004, it created [Leonardo Energy](#), a platform dedicated to accelerating

the energy transition by connecting energy technologies, policies and markets. In 2017, the ECI launched [DecarbEurope](#), a multichannel media campaign with the support of ten industry associations and two media partners. The goal is to engage policy and industry decision makers with cost-effective technical solutions that could each reduce European GHG emissions by 100 to 500 million tonnes per year.

1. THE FUTURE IS ELECTRIC

KEY MESSAGES

The transport and building HVAC sectors together account for about 65% of the EU's final energy consumption. Both sectors traditionally rely heavily on fossil fuels. Decarbonising these sectors can only be successful if a major share of consumption is shifted towards highly-efficient electrical systems running on renewable energy. Since the electricity sector is decarbonising fast, **accelerating this electrification means accelerating the energy transition.**

The solutions to achieve this electrification, such as Electric Vehicles (EVs) and heat pumps, involve the use of electric motor systems.

- Passenger cars driven by electric motors (EVs) have higher well-to-wheel efficiency than cars with an internal combustion engine (ICE) powered by fossil fuels. Concerns about battery capacity and range provide a technological incentive to further increase energy efficiency. The same is true for electric buses and trucks. However, EV motor efficiency depends on the load profile and system boundaries, which complicates how this is evaluated.
- Heat pumps rely on an electrically driven compressor unit and can be used for both heating and cooling in buildings. Heat pumps intrinsically have very high efficiency, which is their major asset. With EU regulations gradually evolving towards imposing nearly-zero-energy buildings, the heat pump sector is stimulated to further drive up energy efficiency. Choosing the right compressor load variation strategy is an important factor in optimising this.

Electric motor efficiency is discussed in more detail in Chapter 2.

To achieve sustainable mass production of electric motors, they should be designed for recycling and should preferably use materials for which availability is not critical. Research & Innovation support should focus on the development of rare-earth-free motors. The place of electric motors in the circular economy is discussed in more detail in Chapter 4.

THE ENERGY TRANSITION NEEDS ELECTRIFICATION

In the traditional energy economy, fossil fuels were used both as an energy source and as an energy carrier. This means that the transition towards a low-carbon society requires not just new sources of energy, but also a shift towards other energy carriers, for which electricity, bio-fuel and hydrogen are the main candidates. Electricity has the advantage that it can be generated from a wide variety of carbon-free energy sources. Solar PV, wind, biomass, hydro, tidal and ocean current systems generate electricity, which is the principal reason why the decarbonisation of our energy economy needs to be linked with increased electrification of energy end-use.

The average carbon intensity of EU power generation has declined sharply since 1990, including a 17% fall between 2009 and 2013. In 2013, the average carbon intensity of low voltage electricity in the EU was 447g CO_{2eq}/kWh [3]. Eurelectric provides a figure of 343 g CO₂/kWh for 2013 and 331 g CO₂/kWh for 2014 for the power generation itself, without calculating losses in transmission and distribution, and without taking into account GHG emissions other than CO₂. [4]

Since 2005, the EU power generation sector has fallen under the Emission Trading System (ETS) and, since 2013, no free allowances are accepted for the power sector, with the consequence that net increases in electricity consumption do not lead to net increases in carbon emissions. The EU power sector is expected to become entirely carbon-neutral by 2050. [4]

Electricity has the additional advantages that:

- It improves local air quality (no local emissions)
- Many of its end-use applications, such as industrial motors, EVs and heat pumps, have very high efficiency
- It is easy to control digitally

The electricity transmission and distribution system is already in place, meaning that large amounts of renewables can be integrated within it in a relatively short time. One disadvantage of electricity as an energy carrier is the storage issue, at large scale and over long periods of time, even though battery efficiency and capacity is making progress with extensive research ongoing. The enforcement of grid interconnections, pumped hydro, demand response and – in the long run – power to gas technology can provide valid alternatives [5].

The share of electricity in gross final energy consumption rose modestly from 17.22% in 1990 [6] to 26.5% in 2016 [7]. During the energy transition in the coming 30 years this share is expected to grow more steeply to 60-70% of final energy use, with hydrogen, geothermal energy, solar heating and various types of bio energy accounting for the remaining 30-40%. The major potential for electrification lies in building heating and cooling, water heating, transport and various types of industrial energy use, most of which involve electric motors.

THE ELECTRIFICATION OF TRANSPORT

The transport sector (private, public and goods transportation) is the largest contributor to energy related CO₂ emissions in the EU-28. In 2015 it was responsible for 28.1% of total final energy use and 28.3% of total energy-related CO₂ emissions. [8, p. 28]

Only a minor part of this transport market is currently electrical, consisting mainly of electric trains, trams, metro systems and trolley buses. However, the market for electric bicycles is rising fast and electric cars are steadily gaining ground. Nonetheless, most of the transport market still uses fossil fuels.

Transport electrification can be achieved in two ways:

- 1) Switching from one means of transport to another. Users can simply shift their preference from a transport system that uses fossil fuels to a means of transport driven by electrical power, for example, travel by high speed train instead of by air.
- 2) Technological revolution within one type of transport vehicle. The most ambitious transition of this kind is from private cars driven by an internal combustion engine with a fuel tank to cars driven by an electric motor with a battery pack. The transition from diesel-powered trains to electrically-driven trains has been going on for several decades; the share of electricity use in rail increased globally from 17.2% in 1990 to 36.4% in 2013 [21].

ELECTRIFICATION OF PRIVATE TRANSPORT

The private transport transition involves 4-wheel electric vehicles replacing internal combustion engine cars, electric two-wheelers replacing motorcycles or bicycles, or the introduction of electric three-wheelers (*tuk-tuks*) and low speed electric vehicles (LSEVs) with limited speed and range. The latter two modes of transport thrive in Asian markets but are not predicted to gain significant market share in Europe; they are therefore not discussed in this paper.

The European market for EVs is growing fast but remains small compared to the market for cars with an internal combustion engine. However, by most predictions, EVs are expected to boom in the coming 15 years.



Figure 1 – Electric car recharging in Berlin, Germany (photo by Michael Movchin, licensed under Creative Commons [CC-BY-SA-3.0](https://creativecommons.org/licenses/by-sa/3.0/))

The main driver for private transport electrification is decarbonisation. Electricity can be generated from various renewable energy sources and used in a highly efficient way in electric vehicles. Even with today's average CO₂ emissions of electricity generation in the EU-28, an **EV produces less than half of the GHG emissions (78 g CO_{2eq} / km) of a similar car with an internal combustion engine and conventional gasoline (185 g CO_{2eq} / km)** (well-to-wheel analysis) [9]. EVs and electric two-wheelers can also bring other advantages:

- 1) They do not contribute to local air pollution owing to the lack of nitrogen oxides (NO_x), volatile organic compounds and particulate matter (PM_{2.5}) emissions. This local air pollution is estimated to be responsible for 5.4% of deaths in Europe [10]. In the example of the city of Rome, if it electrified its

public and light duty goods vehicle fleets, local NO_x emissions would decrease by 34% and PM_{2.5} emissions by 22% [11].

- 2) At low speeds (< 30 km/h), battery electric vehicles emit significantly lower noise levels than ICE vehicles. Some studies claim that for people aged over 65, the mortality due to urban noise could be even greater than that due to PM_{2.5} [12].
- 3) Electro-mobility improves EU energy security. In 2017 the EU-28 had to import 87% of its oil, with 47% of this currently consumed by road transport [13].

Investments in R&D support can also be justified by the aim to anchor the presence of EV industry and make Europe a pioneer in the development of this new technology [14].

With the current technological developments, commonly evoked barriers to electric vehicles such as their high cost and limited range are gradually disappearing. Various commercial electric vehicles on the market already offer a range of over 300 kilometres. One remaining barrier, however, is the lack of fast charging points along the public road network, since slow overnight charging is insufficient to allow for long distance travel (>300 km). In terms of total cost of ownership (TCO), parity between battery electric and ICE vehicles is expected to be reached before 2020. That said, the purchase price of electric vehicles remains higher than that of petrol (gasoline) cars, which can create the perception of high cost.

Well-targeted regulatory measures can help to overcome these remaining barriers and make the transition towards electro-mobility a reality.

EV TECHNOLOGY

There are essentially four types of electric cars:

- *Hybrid electric vehicles (HEVs)* are powered by an internal combustion engine as well as an electric motor with a battery. Power from the engine and the motor can be shared to drive the wheels via a power-splitting device. The battery is charged during regenerative braking (braking energy which is normally lost as heat is converted into electricity) or by the internal combustion engine.
- *Plug-in hybrid electric vehicles (PHEVs)* are HEVs that can be plugged into the grid to charge the battery. The battery has a larger capacity than that found in a HEV.
- *Battery electric vehicles (BEVs)* don't have an internal combustion engine; just an electric drive and a battery pack. The battery is charged by connecting it to the electricity grid.
- *Fuel cell electric vehicles (FCEVs)* are similar to BEVs except that they use a fuel cell instead of a battery pack. The fuel cell uses oxygen from the air and compressed hydrogen (or other suitable gas) to generate electricity, which is then used in the electric drive.

FCEVs can be regarded as sub-optimal because fossil fuel or electricity is used to produce the compressed hydrogen. In the former case, the transport system is not de-carbonised and, in the latter, additional conversion steps are required (the production of hydrogen, compression and reconversion to electricity) which are inherently less efficient than direct use of electricity in the vehicle's motor system. Moreover, hydrogen cars would require new infrastructure and would create safety issues.

HEVs and PHEVs still consume fossil fuel and are therefore merely an interim solution on the way towards full de-carbonisation. In recent years, PHEVs were often seen as the ideal transitional technology leading to fully electrified vehicles, since they provide an answer to consumer anxiety over range and charging times. In the Netherlands, government incentives for PHEVs and BEVs are almost equivalent, resulting in sales figures largely dominated by PHEVs. In Norway, BEV incentives are 65% higher than those for PHEVs, resulting in a market dominated by BEVs [15, p.16]. This demonstrates that the success of PHEVs as a transition towards a

BEV market is largely by government choice. PHEVs can accelerate EV market development but will slow the progress on emissions. With improving battery technology and the range now possible with BEVs, the argument in favour of PHEVs has become largely obsolete. Government policies to support PHEVs risk slowing down the overall progress being made on private transport GHG emissions.

This paper will therefore concentrate only on Battery Electric Vehicles (BEVs).

The following is a schematic representation of BEV technology [15]:

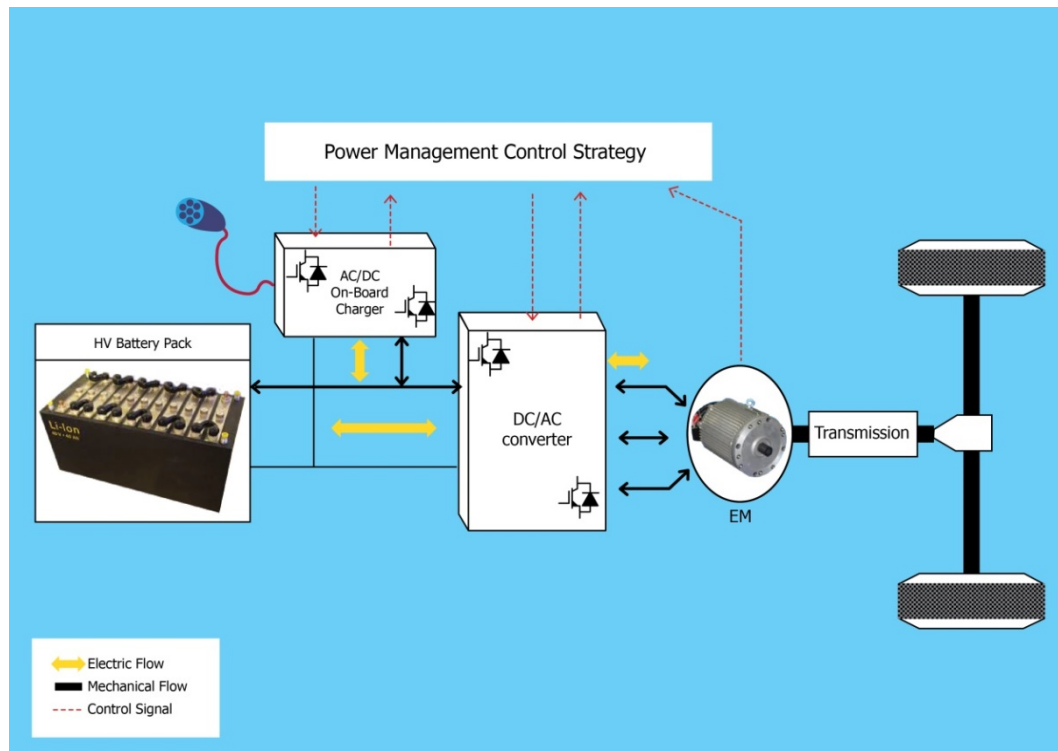

Figure 2 – Schematic representation of BEV technology [15].

TYPES OF EV MOTORS

Various types of electric motors can be used to drive an electric car, with power ratings typically ranging from 15 to 200 kW. With the prospect of a future mass market, electric automotive drives are the subject of intensive R&D efforts, with – among others – a focus on developing motors with zero or reduced rare-earth content. As a result, major improvements leading to shifts between the preferred types of motor are to be expected in the coming years.

The majority of EV manufacturers currently opt for permanent magnet synchronous motors (PMSM). Other types of EV motors include AC induction motors with copper rotors (e.g. Tesla) and synchronous wound field motors (e.g. Renault). The table below summarises the main existing electric vehicle (EV) and plug-in hybrid (PHEV) motor choices in European and US markets:

Vehicle	Vehicle type	Motor type	Specifics
Audi A3 e-tron	PHEV	permanent magnet	rare-earth
BMW i3	BEV	interior permanent magnet	rare-earth
Chevrolet Volt	PHEV	interior permanent magnet	ferrite / rare-earth
Hyundai Sonata	PHEV	surface permanent magnet	rare-earth
Mitsubishi Outlander	PHEV	interior permanent magnet	rare-earth

Nissan Leaf	BEV	interior permanent magnet	rare-earth
Porsche Panamera	PHEV	surface permanent magnet	rare-earth
Renault Zoe	BEV	synchronous wound field	copper windings
Tesla S	BEV	induction motor	copper cage
Tesla X	BEV	induction motor	copper cage
Tesla 3	BEV	interior permanent magnet	rare-earth
Daimler Smart ForTwo ed	BEV	synchronous wound field	copper windings
Daimler Mercedes-Benz B-class ed	BEV	induction motor	copper cage
Toyota Prius	PHEV	interior permanent magnet	rare-earth
VW e-Golf	EV	permanent magnet	rare-earth
VW GTE	PHEV	permanent magnet	rare-earth

Table 1 – Motor types of various EVs and PHEVs. [16]

Major characteristics of the principal motor types [17]:

- The **permanent magnet synchronous motor (PMSM)** has a major advantage in its high torque density and high efficiency at full load. Its main disadvantage is the presence of rare-earth metals in the magnets. These metals suffer from high price volatility, extraction can be polluting, and their concentrated and limited availability could hamper large scale deployment. PMSM motors also have some technical drawbacks. They have a fixed maximum speed and require temperature protection to avoid demagnetisation. A potential solution could be to replace rare-earth metals with ferrite. This results, however, in lower torque density, which means the motor loses its prime advantage, although this drawback has been mitigated by recent developments.
- The **copper rotor induction motor (CRIM)** has a lower torque density and a lower efficiency at full load. However, higher efficiency is reached at high speed / low torque, and the maximum speed can be exceeded for a short period of time. The CRIM is therefore mainly used in top-of-the-range cars (e.g. Tesla [18]). In the future, the output performance, torque density and energy efficiency of CRIM motors for automotive could be improved using special coils, special winding distributions, an outer rotor or even two rotors. [16]
- The **synchronous wound field (SWF) motor** has good torque density and efficiency. Its main drawback is that it needs both AC and DC currents. As a result, battery, converter and power electronics are bigger and more expensive to achieve similar performance as PMSMs. Nevertheless, at least one major EV manufacturer has opted for this type of motor in its cars, which could be a guarantee of further R&D commitment to this type of motor in the coming years. Like the CRIM, the SWFM contains only copper and steel as active materials.
- The **switched reluctance motor (SRM)** could represent a cheap and fault-tolerant solution if its drawbacks can be overcome. Its low power and torque densities, low efficiency, high noise and vibration, and need for a unique inverter control strategy have for now prevented its breakthrough with any of the mainstream EV manufacturers. Potential future improvements, however, could give it the required characteristics for automotive applications. These include optimised winding configurations, closed slot manufacturing, and reduced harmonic content in the airgap magnetic field.

- The **synchronous reluctance motor** could be a promising candidate for the next generation of EVs, these motors have the potential to be high efficiency, low cost, low weight, and low noise, but their relatively low torque densities have made them unsuitable for EVs [19]. Research is ongoing to find ways to increase torque density without compromising other advantages [20].

EV MOTOR EFFICIENCY

The energy efficiency of the drive system is a major issue at the BEV design stage because the energy that can be stored in a battery is limited. As a result, energy efficiency directly affects range – which is one of the major technological attention points of the electric car. Within the context of enhancing range it is beneficial for car manufacturers to invest in drive-system efficiency as long as the incremental cost of this efficiency improvement is lower than the incremental cost of increasing the battery capacity.

But what does “energy efficient” mean in the context of an EV motor? The answer is not straightforward. It can mean the efficiency of the motor, or that of the entire motor system including the cabling and inverter. In some cases, the influence of the inverter efficiency can be just as great as that of the motor itself. Or does it refer to the energy efficiency of the entire car, measured in kWh per kilometre? In this case, the weight of the car also plays a crucial role.

Moreover, the energy efficiency of a drive system also depends on the load. For example: the induction motor has lower efficiency than the PM motor at maximum torque, but the reverse is true at lower torque (see figure below). It is therefore important to know if the expressed energy efficiency of the car relates to the maximum speed or the average speed over the lifetime of the car. The average speed is defined by the EU fuel consumption standard which defines the average driving cycle. However, the load profiles of individual drivers can diverge substantially from this standard, leading to other motors performing better than the supposed top-performers by the official EU measure.

All these factors make it complex to talk about electric car motor efficiency. It is therefore important to clearly define what type of energy efficiency is being referred to when discussing it.

The efficiency of traction drives is sometimes indicated using a colour map representing the entire speed and torque range. The operating points of the driving cycle are plotted on the map to identify the most important regions.

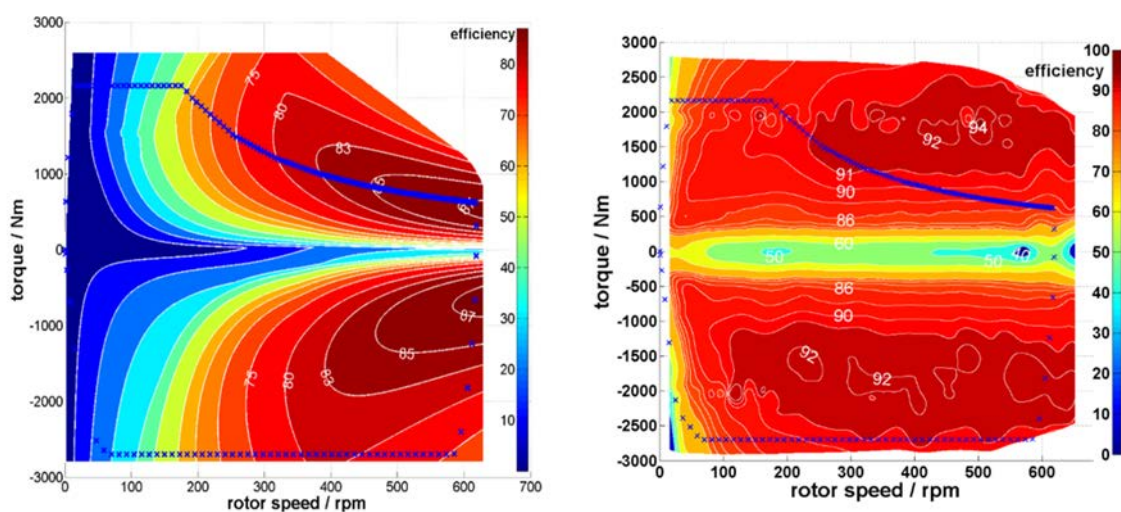

Figure 3 – Efficiency curves of EV motors, an induction motor (left) versus a PMSM motor (right).

EV MARKET PROSPECTIVE

In the **electric two-wheeler market**, data collection and data quality are an issue. Different classifications of two-wheelers are used in different countries and there is a lack of harmonised methodology for data analysis and comparison [21]. What is certain is that China is by far the most dominant market. More than half of the two-wheelers in China are electric, amounting to 223 million units. The prohibition of gasoline-powered motorcycles in many Chinese cities and the fact that electric two-wheelers have reached price parity with motorcycles have contributed to this success. Figures from the UK and Sweden suggest that the European market for electric two-wheelers is also growing at a fast rate, but still an order of magnitude below the Chinese figures. The *Paris Declaration on Electro-Mobility and Climate Change* sets a global deployment target for electric two- and three-wheelers of 400 million units by 2030 (UNFCCC, 2015b). Meeting this target would require a significant increase in uptake of two-wheelers in Europe.

The **four-wheel electric vehicle (EV)** is the most discussed type of private electric transport vehicle. The global EV market is growing fast. According to the *IEA Global Electric Vehicle Outlook 2017*, registrations of electric cars increased by a factor of 5 between 2013 and 2016, with over 750,000 vehicles sold worldwide in 2016 alone[24]. However, market growth is very much concentrated in a small number of countries. In 2016, only six countries reached an EV market share of more than 1% of total car sales – Norway, Netherlands, Sweden, UK, France and China. What has been achieved so far is still relatively insignificant compared to the size of the entire market. Today, EVs represent only 0.2% of the total number of passenger cars on the road, so they still have a long way to go. Research, development and deployment, as well as the prospect of mass production, are leading to a rapid downturn in battery cost at the same time as energy density improvements.

This evolution is accelerated by government policies (see BEV market barriers and drivers).

Globally, Bloomberg expects EV and ICE car sale to evolve as follows:

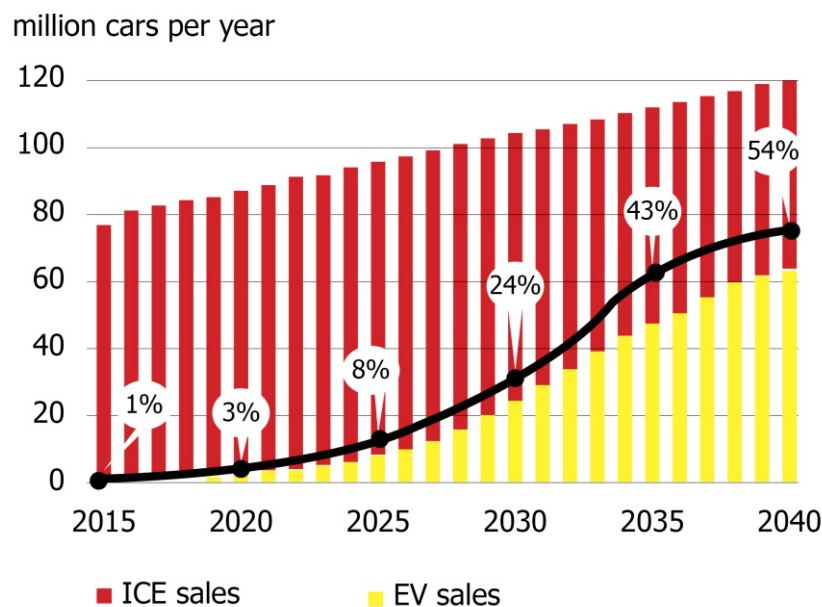

Figure 4 – EV sales prediction 2015 to 2040 (Bloomberg New Energy Finance).

CAN WE GENERATE ENOUGH ELECTRICITY TO CHARGE THESE CARS?

A question that comes up consistently in discussions on EVs is where all that electricity consumed by vehicles will come from. One of the key factors informing the answer to this question is that electric cars are 2.5 times more efficient at end-use than internal combustion engine cars [22]. Because of this high efficiency, the electricity consumption of even one of the larger EV fleets on European roads is limited. The European

Environment Agency (EEA) estimates that consumption from electric vehicles in the EU-28 will increase from approximately 0.03% of the total electricity demand in 2014 to 9.5% by 2050. This was calculated for an 80% share of EVs in the EU car fleet and a total electricity consumption of 260 Mtoe by that time [23]. Moreover, through controlled charging, most of the EV batteries can be charged at times of low electricity demand or high renewable energy production, which can contribute to flattening the electricity demand curve [24, p.42].

In conclusion, large scale EV deployment will require investment to make the European electricity system stronger and smarter, but it will not stretch the system beyond its limits.

BEV MARKET DRIVERS AND BARRIERS

With current technological developments, major technical and financial barriers for electric vehicles are gradually disappearing. Despite this positive outlook it is important to emphasise that a favourable public policies environment is still a crucial driver behind successful EV market uptake. Countries without such a policy environment are lagging behind in the transition. A major remaining barrier is the lack of interoperable infrastructure for fast BEV charging on roads across Europe.

1) Lowering total cost of ownership (TCO)

EV battery prices have been falling steadily over the past few years, from an average of around \$1000/kWh in 2010 to less than \$250/kWh in 2017.

A positive interaction between R&D and market growth is soon expected to further reduce the cost of battery packs. Bloomberg expects lithium-ion battery prices to fall to \$109/kWh in 2025 and \$75/kWh in 2030. This evolution partly depends on, and can be accelerated by, government incentives for battery Research & Innovation.

Reflecting falling battery prices, the total cost of ownership (TCO) of BEVs is also dropping. TCO parity with internal combustion engine vehicles is now predicted to occur before 2020 (based on a life-time of 60,000 kilometres and average EU-28 fuel and electricity prices). In countries with favourable electricity prices and government tax exemptions for BEVs, TCO parity is already being achieved today, as can be demonstrated by the [ECI Passenger Car TCO Calculator Tool](#). This shows that **road tax dispensation can be an excellent regulatory incentive** to stimulate EV market growth.

Even though the BEV is well on its way of becoming the most economical form of individual transport, public awareness does not always follow. Part of the misconception has to do with the fact that people tend to over-emphasise the purchase cost and do not make the TCO calculation. Government stimulation measures are therefore still required to bridge the electro-mobility credibility gap.

2) Government policies aiming to reduce the externalities of transport

Government incentives, such as road tax dispensation, can easily be justified by the fact that BEVs reduce the externalities of road transport. Both GHG emissions and local air pollution are drastically reduced with BEVs compared to internal combustion engine vehicles. Electro-mobility also improves EU energy security and, by making the EU a forerunner in BEV technology, can stimulate the European economy [25].

The transition towards electro-mobility can be stimulated by the EU and its member states through:

- Setting **ambitious targets for the share of renewable energy in transport** in the EU Renewable Energy Directive. It is estimated that the current target will result in nearly 40 million EVs (PHEVs and BEVs) on the road by 2030.

- Set **stringent transport emission targets** in the short term, and a date for a **European wide ban on fossil fuel vehicles** in the longer term. The German Bundesrat has passed a resolution to ban sales of new internal combustion engine cars from 2030 onwards. German regulations have traditionally shaped EU and UNECE regulations. France and the UK have taken similar measures with different time frames. The Swedish, Dutch and Norwegian governments are considering similar bans.

At local level, the transition towards electro-mobility can be stimulated by introducing **low and zero emission zones** in metropolitan areas [26] and through local **pollution charges** (e.g. a circulation tax).

3) Increased range

For a long time, the limited range of electric vehicles was the main barrier to adoption. Simultaneously with falling battery costs, battery energy density has been increasing, leading to increasing EV range. The BEVs on the market today (e.g. Opel Ampera-e, Renault Zoe, Tesla 3...) offer a real range of more than 300 kilometres. While this is still less than the average range of an ICE vehicle, the problem is at least partly one of perception. The average trip is 15 kilometres in the US and less in all other countries of the world. This means that electric vehicles have enough range for most car trips made by European drivers. For such short trips, battery charging can be done overnight at home through a 3.7 kW wallbox in less than 3 hours [27, p. 62]. For longer distances, BEVs would require fast 150 kW chargers installed along the road network at regular intervals (see Point 4).

4) Charging infrastructure

The lack of public charging stations is the final major barrier for the development of EVs. It was indeed identified as the principal barrier to EV mass market roll-out in the European Commission's *Green eMotions* study, published in 2015 [28]. It is a classic chicken-and-egg dilemma: where should investment go first? EVs or the charging infrastructure? In the meantime, early-adopter countries like Norway have demonstrated that governments should invest in both at the same time.

Three major types of charging infrastructure should be developed:

- Private, slow:** 3.7 kW wallboxes for slow overnight charging at private parking places within buildings. In its legislative proposal to amend the April 2017 Energy Performance of Buildings Directive, the European Commission has taken the initiative to set minimum standards for electric vehicle re-charging infrastructure in both residential and non-residential buildings. For example, at least one in ten parking spaces in new non-residential buildings and those undergoing major renovation will have to be equipped with a recharging point [29].
- Public, slow:** 3.7 kW charging stations for slow overnight charging in residential parking areas in the street. Cities should make provision for specific parking spaces for electric vehicles with a 3.7 kW pole, with a procedure similar to how parking spaces for disabled drivers are allocated. For professional urban transport (taxis and small vans), a 7.4 kW point at depot/parking/street level for overnight charging could be installed. Amsterdam sets a good example, with 30,000 unique users of the city's public charging stations in one month (February 2017). Residents and businesses can request an EV charger in their street, and it will normally be installed within a few weeks. Such projects can pave the way for more general European roll-out of charging infrastructure [30].
- Public, fast:** When travelling longer distances outside BEV range, fast charging along highways should become an option. A network of 150 kW chargers should be placed every 50 kilometres along main highways (TEN-T core network). Since the local electricity grid may lack the capacity to connect such high-power charging stations directly, in-situ battery packs may be required to balance the energy

uptake from the grid. The roll-out of such networks is probably the biggest challenge and the most pressing urgency in the transition towards electro-mobility in Europe.

The harmonisation of standards and the interoperability of charging stations is an issue. Appropriate ICT platforms with non-proprietary interfaces should be developed so that EV drivers can use public charging infrastructure independent of owner or operator [31]. There is also a need for clear and internationally-agreed signage. Government policies could help the development of harmonised standards, interoperability and consistent, universal signposting.

ELECTRIFICATION OF PUBLIC AND GOODS TRANSPORT

The contributions of the various transport modes in the EU in 2015:

	Passenger Pkm	Freight Tkm	Total TU
Road	82.2%	50.8%	71.5%
Air	9.9%	0.1%	6.6%
Maritime and inland waterways	0.3%	37.2%	12.9%
Rail	7.6%	11.9%	9.0%

Table 2 – The contribution of the four main transport modes in the EU in 2015 (Based on EC (2017) and UIC (2016a)).

RAIL TRANSPORT

Of all transport modes, rail transport produces the least CO₂ emissions and they are also decreasing at the fastest rate. The 2017 UIC-IEA Railway Handbook [8] provides the following key figures in relation to the EU:

- CO₂ emissions per railway transport unit (a weighted combination of passenger-km and freight tonne-km) fell by 45.2% between 1990 and 2015. Several factors contributed to this:
 - The proportion of electrified railway kilometres rose from 43% in 1990 to 61% in 2015. Since 2009, however, railway network electrification in the EU has faltered.
 - Despite this stagnation in network electrification, the shift from diesel locomotives to electric locomotives continues. Diesel locomotives are expected to fall in number from 13,300 in 2010 to 9,100 by 2020, while the electric locomotive count is expected to rise from 7,100 to 11,100 in the same period [32]. Failing further electrification of the network, however, this shift will also ultimately plateau.
 - The share of fossil fuels in the EU railway energy mix (primary energy) decreased from 78.5% in 1990 to 61.2% in 2015 because of electrification and the increased use of renewable energy.
 - There has been a gradual transition from tap-changer controlled locomotive to inverter-driven types featuring regenerative braking. In 2016 Deutsche Bahn (DB) reported an average regeneration rate of 6.9% for freight trains, 11.4% for long-distance passenger trains and 19.2% for regional passenger trains. Although the transition is not yet complete, the trend continues.

As a result, the contribution of rail to total EU transport CO₂ emissions fell from 5.7% in 1990 to 2.9% in 2015

- The growth of rail transport did not keep pace with the growth of the total EU transport sector in the period between 1995 and 2015, dropping from a 10% share in 1995 to 9% in 2015.
- The share of high-speed rail passenger numbers compared with total rail passenger numbers increased from close to zero in 1980 to 27% in 2008, and then began to level off, growing to just 29% in 2015.

The power of an electric railway engine typically ranges from 3.5 to 7.5 MW. There has been a gradual transition from DC or AC motors with series field windings to AC induction or synchronous motors with variable speed drives (VSDs) which enable regenerative braking.



Figure 5 – Deutsche Bahn Class 146 Electric locomotive (Photo by Clic, licensed under Creative Commons ([cc-by-sa/4.0](https://creativecommons.org/licenses/by-sa/4.0/))).

Electric motors of this size have high energy efficiency. There is undoubtedly still room for some incremental energy efficiency gains, but setting minimum energy performance standards is not a realistic option for this kind of motor. The motors are designed for one specific series of locomotives, due to which the setting of a baseline and market surveillance would be close to impossible. Moreover, energy efficiency gains can also be achieved by a continued conversion towards motors that enable regenerative braking, and through electronic driver assistance systems that optimize the braking behaviour of the train. The electronic converters driving the motors have high efficiency (typically 94-98%) and the development of advanced power electronics can further reduce the converter losses. Stimulating a continuous attention to life cycle costing within the railway infrastructure companies can be a good way to ensure that such relatively minor energy efficiency improvements remain worthwhile.

Greater decarbonisation potential lies in the further electrification of the existing railway network. Although total electrification is probably not realistic in the short term for economic reasons, there is certainly still room for progress. And as the share of renewable energy in the electricity mix continues to rise, the benefits of further electrification in terms of CO₂ emission reductions will become even more substantial. EU-wide regulatory support that could help reap this benefit is currently lacking, and the pace of electrification is faltering. When formulating such support, however, care should be taken that harsher regulations concerning diesel locomotives do not result in them being taken out of service with customers shifting instead to road transport. This would have a retrograde effect on environmental issues. This plea for well-thought-out regulation was expressed in the European Commission's CLEANER-D (Clean European Rail - Diesel) project final report in 2014 [33].

Additional decarbonisation potential lies in the further development of high-speed railway lines that can compete with short distance aviation. Along with the electrification of existing lines, the construction of new high-speed lines slowed considerably after 2008. Creating a favourable investment climate for this technology

again could be achieved indirectly through fair taxation of the externalities of aviation (see chapter Marine and air transport), as well as directly through development support. Environmental protests have been a feature of new high-speed railway lines, but the arguments used can be countered in three ways:

- Emphasising the substantial environmental advantage of high-speed rail transport compared to other transport modes;
- Ensuring that local, lower-speed railway services are not reduced or eliminated;
- Demonstrating that disused railway lines are being transformed into *voies vertes* for cyclists and pedestrians, showing that railways can give back to nature too.



Figure 6 – A German ICE high-speed train, consisting of two units of 8 MW each (photo by S. Terfloth, licensed under Creative Commons ([cc-by-sa/2.0](https://creativecommons.org/licenses/by-sa/2.0/))).



Figure 7 – A disused railway line in France transformed into a ‘voie verte’ (source: Office de Tourisme d’ Amélie-les-Bains).

FREIGHT TRANSPORT WITH TRUCKS

Trucks, buses and coaches represent fewer than 5% of road vehicles in the EU but generate around 25% of road transport CO₂ emissions. Even if some of this traffic could be diverted to rail, road transport has the advantage of providing door-to-door service and is so huge that it will continue to play a major role in the future. Electrification of this heavy-duty transport is advancing more slowly than for cars and will probably not

be widely commercially available until 2020-2025. Nevertheless, rapid progress is being made here too. In the past two years, several major companies have been positioning themselves to offer technological solutions in this sector. [34]

In November 2017, Tesla unveiled its plans for a semi-autonomous electric truck, with a range of 800 kilometres, for which production is due to start at the beginning of 2019 [35]. Other manufacturers introduced electric trucks to the market in the second half of 2017: Cummins with its Class 7 electric truck, and Loblaw Companies Limited's Class 8 electric truck [35]. In 2017, Daimler launched a limited edition production run of its battery-powered Mercedes-Benz electric truck, designed for package and goods deliveries within cities [36]. Nikola Motor Company, however, have opted for a system with hydrogen as an intermediate energy carrier, reconvertng it to electricity onboard. The *Nikola One*, with a range of more than 1100 kilometres, is currently in pilot version and the first customers are expected to take delivery in 2020.

One potential drawback of electric trucks is the size and weight of the battery, which reduces the loading capacity of the truck. However, with battery technology evolving, this barrier is gradually being overcome. An average truck will require a 500-kWh battery for a range of 400 kilometres. This range corresponds to the mandatory 45-minute stop a truck driver must make every 400 km under EU regulations. With current technology, such a battery would add 4-5 tonnes to the weight of the truck, but this needs to be set against the weight of the diesel engine it replaces, and other weight savings in the powertrain. Electric trucks also save on energy and maintenance costs. [37] Battery energy density is improving at a rate of approximately 4% per year, which means that a weight reduction by a factor of 30-40% could be expected by 2030.

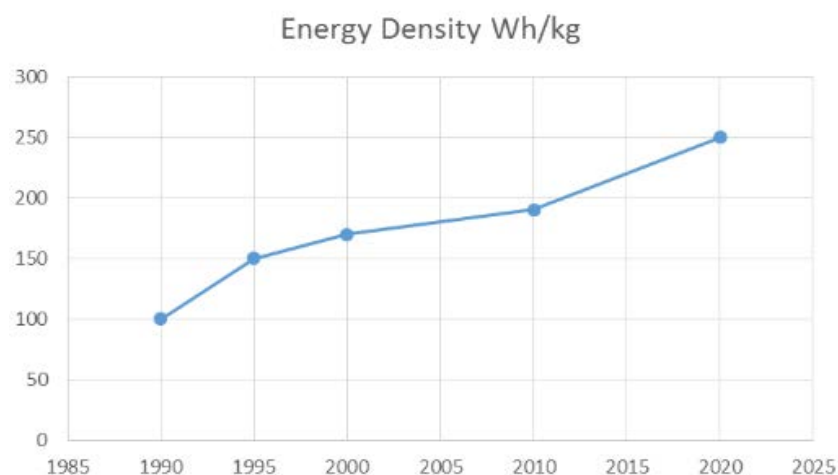

Figure 8 – Performance increase of Lithium-ion batteries [38].

A second drawback is the powerful charging infrastructure electric trucks would require. At overnight truck stops, charging points of 100 kW would have to be installed so that trucks can recharge in 5 to 6 hours. Along highways, fast charging points would be needed with a power of not less than 1 MW to match charging times to drivers' mandatory rest periods.

Both drawbacks could be eliminated using hydrogen as an intermediate energy carrier, as in the *Nikola One*. Electricity is converted to hydrogen at the loading station and converted back into electricity by an on-board generator. The downside, however, is that this leads to a substantial loss in well-to-wheel efficiency.

The complexity of rolling out a powerful charging infrastructure raises the question of whether it would not be smarter to develop e-highways with overhead lines to which the trucks can connect with pantographs. A 2 km test lane has recently been installed near Stockholm, Sweden [39]. A truck can draw power to recharge its electric battery while on highways equipped with overhead lines, and then use it to travel on secondary roads.

Such a system lends itself to being combined with a self-driving mode built into the truck control system, which would allow trucks to drive much closer to each other on the highway without compromising safety, providing an effective solution for highway congestion.



Figure 9 – Around 32 million trucks took to EU roads in 2015 [40], with motive power ranging from 100 kW to 600 kW (Photo by [Glyn Baker](#) licensed under Creative Commons ([cc-by-sa/2.0](#))).

PUBLIC TRANSPORT WITH BUSES

The electrification of bus transport is developing faster than for trucks, even though diesel fuel and compressed natural gas (CNG) still dominate the market.

In 2017 there were around 385,000 e-buses on the road, or a little over 10% of the global bus fleet. 99% of those e-buses were in China and 0.5% in the EU (2,100 units). Domestic demand in China is heavily driven by national sales targets, supportive subsidies and municipal air-quality targets. Major cities such as Shanghai and Shenzhen have halted purchases of internal combustion engine buses entirely. The share of e-bus sales in China increased from 0.6% in 2011 to 22% in 2017. E-buses now represent 17% of China's total bus fleet [41]. Battery-powered electric e-buses dominate the market compared with plug-in hybrid buses.

In October 2017, the mayors of 12 of the world's largest cities pledged to procure only zero-emission buses from 2025 [42].

For city buses, driving electric makes a lot of sense. Their power is limited compared to trucks and they cover shorter distances (urban buses have a typical daily range of 200-300 km), so the battery can be charged overnight at the depot. The total cost of ownership of electric city buses will reach parity with Diesel Euro6 bus models before 2020, as demonstrated by a Columbia University study for New York City Transit. According to the study, the payback period for a higher priced electric bus would be 8 years (for a bus with a 12-year lifetime) thanks to lower fuel and maintenance costs [43].

MARINE AND AIR TRANSPORT

Of all transport modes, marine and air transport are the furthest away from a market-ripe carbon free solution.

Nevertheless, some electric vessels are already on the water and proving effective. They are mostly small boats covering short distances, such as tugs and short-haul ferries. Their batteries are normally charged by plugging in to the general AC power supply, sometimes combined with on-board solar cells [44]. For larger ships covering greater distances, battery technology currently still falls short of the required specifications to make electrification a viable option. As the technology stands now, biofuels are a more realistic path towards decarbonisation for this segment of marine transport.

Aviation is taking a major and growing share of passenger transport kilometres (9.9% in 2017, Table 2). Less information about what manufacturers are developing in aerospace electrification is available than for road transport electrification. Nevertheless, it is clear that a zero-carbon solution for air transport is still a few major steps away. An increasing number of functions in airplanes are being electrified, resulting in energy efficiency improvements, but this electricity is still generated by kerosene-powered jet turbines. Full electric propulsion by motor-driven fans is a major technical challenge due to the limited capacity/weight ratio of electrical batteries. Flying electrically has been achieved in experiments with smaller planes – the largest of which have just under 1 MW of power. For comparison, a Boeing 777 with two GE90-115B jet engines has a total power of 164 MW.

A Siemens, Rolls-Royce and Airbus consortium is developing a small business aircraft with one of its four motors consisting of a 2 MW electric fan. This hybrid-electric aircraft is due to be unveiled in 2020 [45]. Even though this development is encouraging, and smaller short haul aircraft might be on the road to electrification, the development of large fully-electric aircraft has an uncertain time horizon. They most probably should not be expected to arrive in the next ten to twenty years. Due to weight restrictions, aircraft flying entirely on biofuels are also not a viable option, although liquid hydrogen fuelled planes could be an option in the longer term.

Shifting customers from air to high-speed rail is one of the most effective paths to decarbonisation. For journeys under 1000 km, there is generally little difference in journey time, since time getting to and from the airport and passing through security checks has to be factored in. Government incentives to stimulate such a shift could form part of development support for the European high-speed railway network along with the enforcement of stringent EU Emissions Trading System (EU ETS) obligations for passenger flights.

THE ELECTRIFICATION OF HEATING AND COOLING

40% of Europe's energy use and one third of greenhouse gas emissions can be attributed to buildings, and much of this relates to heating and cooling [46].

With the Energy Performance of Buildings Directive (EPBD), the EU aims to decrease emissions from residential and tertiary sector buildings by 88-91% by 2050 compared to the 1990 baseline. To achieve this target, significant actions need to be triggered in EU national building markets [47]. This requires a holistic approach combining a reduction in the heating and cooling needs of the building with highly energy-efficient heating and cooling systems.

Since the construction and renovation rates are low, a heating or cooling technology installed in a building could remain for 30 to 40 years or more – the technology will effectively be “locked in”. This means that systems should be designed with the future in mind, considering in particular the expected rate of CO_{2eq} emissions from electricity generation. This figure is due to decrease from 447 gCO_{2eq}/kWh in 2013 to 230 kgCO_{2eq}/kWh in 2030 and close to zero by 2050. Any regulatory policy on heating and cooling systems in buildings should take this evolution into account.

The preferred type of heating technology for each dwelling depends on many factors, but a major influencing element is the insulation level that can be obtained in the building:

- At the higher end there are newly constructed or deep-renovated buildings with a combination of state-of-the-art insulation, maximum use of direct sunlight, and a ventilation system with heat recuperation that can reduce the energy requirement for space heating to zero (passive building) or close to zero (very low energy building). In the latter case, simple electric heating elements can be installed in some of the rooms, meaning that the heating is electrified, but without the use of electric motors.
- At the lower end there are old, sometimes historic buildings for which the insulation potential remains very limited. In such cases, a central heating system with a wood pellet boiler will often be considered, even though there is uncertainty to what degree this kind of system can be carbon neutral. Factors include the source of the wood, GHG emissions from production and transport, and what time scale is appropriate for carbon neutrality assessment. In addition, wood pellet combustion results in substantial emissions of particulate matters PM_{2.5}.
- Most residential buildings lie between the two extremes. For these dwellings, a local heat pump or a highly decarbonized district heating system are the preferred options to reduce carbon emissions. A heat pump takes a major share of its useful energy from the environment and has an electrically driven compressor as its active component. With the upcoming decarbonisation of electricity generation, its carbon emissions will gradually evolve to zero. Since heat pumps rely on electric motors for their operation, they are discussed here in further detail.

HEAT PUMPS

Heat pumps do not create heat, but pump renewable, cost-free heat from a low temperature source to a higher temperature space where it is needed. It can be used both for space heating and for sanitary hot water. By reversing the cycle, the same heat pump can also be used for cooling in the summer. This can significantly reduce the energy costs and carbon emissions of air-conditioning systems in residential, office building and industrial environments. The same principle is also used in domestic and industrial refrigerators, freezers and chillers.

Two different types of energy are fed into the heat pump cycle:

- Passive energy, in the form of free and renewable low-temperature heat from the ambient air or water. It normally contributes 60-75% of the total heat pump power.
- Active energy, in the form of an electric motor driving a compressor (and often also one or more pumps for the ground loop and/or heating distribution system), accounting for 25-40% of the heat pump energy use.

As a heat source, the system can use external air, pipework installed in the earth, a well or borehole, or a local watercourse or pond. Typical capacities range from 2-10 kW for single family units to 100 kW for multi-dwelling residential buildings.

The environmental advantages of heat pumps are compelling. According to statistics compiled in 2015, a heat pump typically **saves 40-60% of GHG emissions compared to a natural gas boiler** with the same heating capacity. These savings will continue to rise as the electricity emission factor continues to decrease. Once electricity generation is entirely free of carbon emissions, the heat pump will represent a very efficient zero-carbon heating system. Heat pumps already function as zero-emission systems today when combined with local PV generation and battery storage. A further advantage of heat pumps is that **there are zero local pollutant emissions (NO_x, fine particles, CO)**.

	Direct electric heating	Natural gas heating (new boiler)	GSHP	ASHP
Annual heat load	200,000 kWh	200,000 kWh	200,000 kWh	200,000 kWh
Typical average efficiency	100%	90%	340%	260%
Annual energy consumption	200,000 kWh	222,222 kWh	58,824 kWh	76,923 kWh
European average CO ₂ emissions factor	0.447 kgCO _{2eq} /kWh	0.220 kgCO ₂ /kWh [48]	0.447 kgCO _{2eq} /kWh	0.447 kgCO _{2eq} /kWh
Annual carbon emissions	89,400 kgCO _{2eq}	48,889 kgCO _{2eq}	26,295 kgCO _{2eq}	34,385 kgCO _{2eq}

Table 3 – Comparison of typical carbon emissions for direct electrical heating - gas boiler, ground source heat pump (GSHP) and air source heat pump (ASHP) for a building with a heat load of 200,000 kWh/year [47]

THE WORKING PRINCIPLE OF THE HEAT PUMP

A heat pump is based on a refrigerant cycle similar to that in a refrigerator or air conditioning system. It consists of a closed circuit with a cool, low pressure side, and a hot, high pressure side. The main points of heat pump operation are:

- The cool ambient air or water volume, which serves as the energy source, gives off heat to the even cooler transfer fluid (refrigerant). Since the refrigerant is under low pressure, it uses this heat in evaporation. (1)
- A compressor driven by an electric motor unit, compresses the refrigerant, which increases its temperature and its boiling point. (2)
- The high temperature, high pressure vapour is fed into a heat exchanger, where the energy is transferred to a heat sink (e.g. ambient air or a heating distribution system). The refrigerant vapour cools down and condenses, although it remains at a fairly high temperature. (3)
- Pressure is released through an expansion valve. The boiling point returns to the low-pressure temperature level, and the refrigerant starts to boil. Boiling absorbs a considerable quantity of heat and makes the temperature drop below that of the ambient heat source, and the cycle is closed. (4)

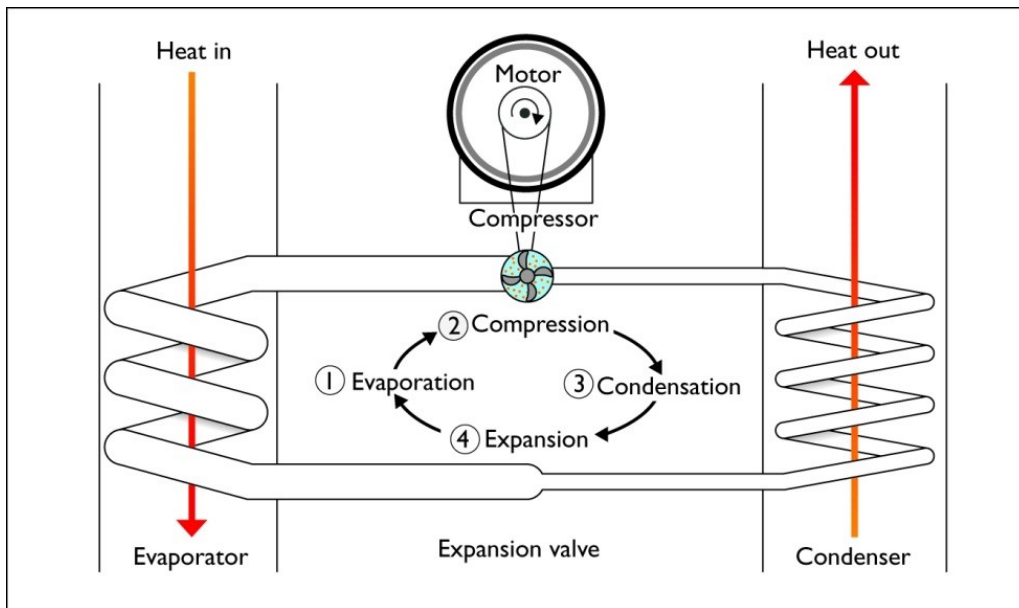

Figure 10 – Working principle of the heat pump [47].

On the evaporator as well as the condenser side, the heat transfer can be direct or via an extra cycle:

- The condenser can be used to directly heat a space, or it can transfer heat via a system of radiators or an underfloor heating system throughout the building.
- The evaporator can draw heat from air, ground or surface water directly (known as “direct expansion”), or it can be connected to an extra refrigerant loop.

Heat pumps with only one loop are generally limited to small air source heat pump systems. Heat pumps with three loops generally are ground or water source systems and are used for larger buildings. Most residential and small office heat pumps combine direct expansion on the evaporator side with an extra heat distribution loop on the condenser side.

The additional refrigerant or heat distribution loops require a pump to move the fluid. These (small) pumps are driven by an electric motor, which self-evidently reduces the overall efficiency of the system. However, multi-loop systems can sometimes gain this back with more efficient heat transfer. There are also practical and financial considerations making it advantageous to opt for multi-loop systems. The question of which is the best heat pump system in terms of investment cost, life-cycle cost and energy efficiency needs to be evaluated case-by-case.

HEAT PUMP PERFORMANCE

One of the main ways in which heat pump performance can be characterized is the COP:

$$\text{Coefficient of Performance (COP)} = \text{useful heat delivered} / \text{electric compressor power}$$

Heat pump COP typically fluctuates between 3 for an air source heat pump (ASHP) and 5 for an efficient ground source heat pump (GSHP).

The average heat pump COP over an entire heating season, known as the seasonal performance factor (SPF), is an measure of heat pump efficiency. It is used to accurately compare different heat pump installations across different climates, as well as to compare CO₂ emissions and primary energy use of heat pumps with those of fossil fuel heating systems.

HEAT PUMP COMPRESSOR UNIT, INCLUDING THE ELECTRIC DRIVE

The major energy-consuming element in a heat pump is the compressor system driven by an electric motor, hence the importance of optimising its energy efficiency. Which type of compressor system has the highest efficiency depends on several factors, including the maximum power it requires or whether the compressor can run efficiently when partially loaded.

Response to load variation

Response to load variation can be achieved through on-off regulation or by varying the speed.

In medium or large heat pumps using an extra refrigerant loop, the system has enough thermal inertia to opt for *on-off regulation*, switching between stand-by and full load. A further option is to make use of a *two-speed compressor*, which makes it possible to shadow the required heating or cooling capacity fairly efficiently. Two-speed heat pumps work well with zone control systems keeping different rooms at different temperatures. Large heat pump systems can also use *smaller compressors in parallel* to obtain a wide range of load variation response.

Direct expansion systems generally reach higher efficiencies by using a multi-speed compressor and a motor that can operate in the whole range between 0 and 100% of the full load. They are mostly driven by a combination of permanent magnet synchronous motors (PMSM) and a variable speed drive (VSD). These systems are commonly called *inverter* heat pumps.

Optimizing the efficiency of the entire unit including the motor, drive, starter and compressor for the estimated load profiles of the heat pump

The new international standard on motor driven systems (IEC 61800-9 Parts 1 and 2) specifies how to minimise the energy losses in the entire system of motor, drive, starter and compressor. Starting from an estimation of the load-time profile of the heat pump, its efficiency in various part-load situations can be calculated to arrive at the energy efficiency index (EEI). By comparing the estimated EEI values of various load profiles, the best-performing heat pump system can be determined. IEC Standard 61800-9 is discussed in greater detail in Chapter 2, “Going beyond the component approach”.

Compressor types

For smaller compressors (up to around 50 kW), reciprocating types are an energy-efficient option.

Compressors for large buildings are typically either centrifugal or scroll-type. Centrifugal compressors generally offer higher full-load efficiency than scroll compressors, whereas scroll compressors tend to maintain better efficiency when operated at part load and so are the preferred choice in direct expansion heat pump systems. [49]

Motor types

In smaller heat pumps, the electric drive and the compressor are supplied as a single sealed unit, with energy-efficiency labelling covering the whole unit. If the compressor and the motor are two separate units, premium efficiency IE3 or super premium efficiency IE4 motors should be used.

Traditionally, heat pump compressors have been driven by an induction motor. This is still the preferred option for fixed-speed and dual-speed compressors. For two-speed compressors, dual speed induction motors with a Dahlander winding configuration are preferred [50].

In multi-speed compressor systems, the motor unit is equipped with a variable speed drive (VSD). This slightly reduces energy efficiency at full load but increases efficiency at partial load. Various motor types are used in

combination with a VSD, including induction motors and permanent magnet synchronous motors (PMSM) [51]. Since weight and size is not an issue for heat pumps, their PMSM motors are normally built using ferrite, which means that they are free of rare-earth metals. Synchronous reluctance motors and switched reluctance motors are gaining ground in this area. The latter is combined with a low cost VSD but has high torque ripple and related noise level.

For an estimation of the market growth of electric motors associated with the increased use of heat pumps in the EU see the Annex.

GOVERNMENT POLICIES STIMULATING HEAT PUMP DEPLOYMENT

Since heat pumps are a highly-efficient, low-carbon (and in the future zero-carbon) heating and cooling systems with no local emissions, government policies to stimulate the heat pump market can be readily justified.

Heat pumps are economically efficient when calculated over the entire life cycle of the system, but the initial investment cost is generally higher than that of other heating systems. Regulatory measures can mitigate this barrier to adoption. As the heat pump market continues to grow, economies of scale will further put downward pressure on prices while also increasing efficiency.

EU regulation to stimulate the heat pump market currently ranges across various regulatory fields, reflecting the fact that a heat pump is both an energy-consuming device and a source of renewable energy.

The EU **Renewable Energy Sources Directive (RED)** takes heat pumps into account where they reach a minimum SPF. Once the SPF is above the minimum value of that year, all energy that is contained in the system additional to the electrical input power of the compressor is considered to be renewable and is counted as a contribution towards EU renewable energy targets. This minimum is calculated according to the formula $SPF > 1.15 / ETA$. With:

- ETA = average efficiency of EU power production
- ETA = total gross energy production / primary energy production, calculated with EU averages based on Eurostat data [52]
- $1 / ETA \approx$ the primary energy factor (PEF).

In 2016, the minimum SPF value was 2.875.

The EU **Ecodesign Framework Directive for Energy Related Products** contains the Implementing Regulation No 813/2013 on space heaters and combination heaters, including heat pumps, which came into force on 26 September 2017. It sets minimum energy efficiency and maximum emission levels for each kind of heating technology (see also *Heat pump system efficiency*) [53]. Regulation No 811/2013 under the same directive prescribes an energy label for space heaters and combination heaters, with levels from A+ to G, allowing functionally equivalent heat generators to be compared based on efficiency. The labelling is independent of the energy source used, covering fossil fuel combustion boilers, solar thermal systems, electric or thermally driven heat pumps as well as cogeneration. The basis of comparison is the primary energy efficiency, without taking account of the heat drawn from the ambient air or water. As a result, heat pumps have primary energy efficiency values of 250 – 400%, setting them in the highest efficiency category.

The proposed update of the EU's **Energy Efficiency Directive** contains specific provisions to promote energy efficiency in heating and cooling, a domain where heat pumps excel. The 2012 Directive includes a set of binding measures to reduce by 20% the EU's primary energy consumption by 2020, compared to 1990. The update proposes a new set of measures to increase this figure to 32.5% by 2030.

The EU **Energy Performance of Buildings Directive (EPBD)** sets minimum requirements for the energy use of buildings. From 2021, the “nearly zero-energy building (nZEB)” will be the mandatory standard for all newly constructed or deep renovated buildings. This means that the building should have very high energy performance, and that the *“very low amount of energy required should to a very significant extent be covered by energy from renewable sources, including renewable energy produced on-site or nearby”* [54]. A heat pump sustained by local renewable energy is one of the primary HVAC options for a nearly zero-energy building.

However, the housing renewal rate in the EU is less than 1% year-on-year [55], which means that the evolution is too slow if it depends on new construction only. The renovation rate for residential buildings is not much higher – around 1% [56]. **To reach the 2050 EPBD targets, the renovation rate should be greatly increased.** Detailed studies reveal a strong correlation between renovation rates and the economic output (GDP) of a region [55]. To increase this rate above this natural rhythm, government incentives will be required. The European Commission recognises this, since it has stated in the new, revised EPBD that *“EU countries will have to establish stronger long-term renovation strategies, aiming at decarbonising the national building stocks by 2050, and with a solid financial component”* [57]. This revised EPBD was formally endorsed by the European Parliament on 17 April 2018 and by the EU Council on 14 May 2018. The question remains whether it will prove to be a sufficient driver for member states to put measures in place that would significantly boost building renovation rates.

Given the importance of HVAC in any large-scale carbon emission reduction plan for Europe, and given the multiple advantages of heat pumps in this respect, the currently existing measures should be taken to the next level. This can be done by [58]:

- Setting more stringent minimum efficiency performance standards (MEPS) for the less efficient heating systems in the Ecodesign Directive;
- Actively stimulating member states to put incentives in place to boost renovation rates of existing buildings.

To ensure that the contribution of heat pumps to the decarbonisation of the economy is fully taken into account, it is crucial that the **primary energy factor (PEF)** is calculated using the Fraunhofer Institute’s scientific methodology [59] and reviewed regularly so that it continues to accurately reflect changes in the energy mix.

ELECTRIFICATION OF PNEUMATIC AND HYDRAULIC SYSTEMS

There is a trend in industrial automation and robotics to switch from pneumatic or hydraulic systems to a purely electrically-driven system with electromechanical actuators [60 and 61]. This means that one electric motor driving a compressor or pump is replaced by many electric actuators at the point of use. Whether this is advantageous from an economic and functional point of view depends on many parameters, such as the required speed, torque, precision and intensity of use.



Figure 11 – An electrical actuator on a valve in a power plant (Wikipedia, by Khepster, published under the Creative Commons [Attribution 3.0 License](https://creativecommons.org/licenses/by/3.0/)).

Generally, an all-electric system has a higher initial cost but will in many cases have a lower life-cycle cost. This is mainly because electric systems do not draw power when no motion is required. Pneumatic and hydraulic systems, on the contrary, continuously use energy to maintain pressure levels. Pneumatic systems are also very susceptible to leaks, while hydraulic systems generally have poor overall energy efficiency (typically around 50%). Moreover, all-electric systems have lower maintenance costs, since they have fewer components and do not require leak repair, among other factors.

Apart from life cycle cost, all-electric systems can also have operational advantages, such as much better motion control: accuracy, repeatability and co-ordination of multiple actuators. They also achieve a higher power maximum than pneumatic systems (up to 178 kN) and are easier to install than hydraulic systems.

Nevertheless, not all pneumatic and hydraulic systems are suitable for electrification. Hydraulic systems will for instance remain best practice in applications requiring a very high pressing power.

Today, however, pneumatic and hydraulic systems are still commonly found in cases where an all-electric system would be beneficial over the lifetime of the installation. The more traditional systems are often preferred because they are better-known by decision makers and operators, and because of their lower initial purchase and installation cost.

2. INCREASING THE ENERGY EFFICIENCY OF MOTOR SYSTEMS

KEY MESSAGES

As described in the previous chapter, the number of electric motor systems in use is expected to rise rapidly with the increased electrification of transport, heating and various industrial applications. This makes the energy efficiency of these motor systems even better leverage to reduce GHG emissions. Well-attuned regulatory instruments can achieve substantial impact in this field.

EU Regulation 640/2009 has been successful in setting out minimum efficiency performance standards (MEPS) for electric motors of medium size, changing the market from predominantly low efficiency (IE1 and IE2) motors to a market of predominantly higher energy efficiency motors (IE3).

Extending the Ecodesign MEPS to other motor categories and removing some exceptions would be a logical next step, more precisely:

- Including small single and three-phase motors
- Including large motors of low or medium voltage
- Removing the exception for brake motors and explosion-proof motors
- Removing the choice to opt for IE2 if combined with a variable speed drive (VSD), setting IE3 with a VSD as the mandatory efficiency level

Those four steps would lead to **a total saving of 22.3 TWh or 9.97 million tonnes of CO_{2eq} per year.**

The final point above is viewed as imperative, since there are no technical grounds for the exception to persist, and the VSD market will continue to grow without such stimulus. Since VSDs are not the most energy-efficient options in all cases, retaining this exception could damage previous efforts and transform savings into losses.

For medium and large power motors, the minimum efficiency level could be raised to IE4 from 2022 onwards. Doing so would be economically sound and would **save an additional 9.3 TWh and 4.16 million tonnes of CO_{2eq} per year.**

Incorporating the notion of system efficiency into an “extended product approach” is difficult to translate into a workable regulation. A **more active promotion of standard IEC 61800-9** would be useful, as well as the development of a software tool that can assist in implementing this standard. Another – complementary – way is **to promote motor system efficiency via the ISO 50001 standard on Energy Management** and its implementation guides.

THE TRANSITION TOWARDS INCREASED MOTOR EFFICIENCY

Much has been achieved around the world since 1995 to bring steadily increasing energy efficiency to electric motors available on the market.

The energy efficiency of stand-alone 50 Hz electric motors is defined by the international standard IEC 60034-30-1 (2014 version). This standard envisages six efficiency categories, the lowest being uncategorised and the rest ranging from IE1 (Standard Efficiency) to IE5 (Ultra Premium Efficiency).

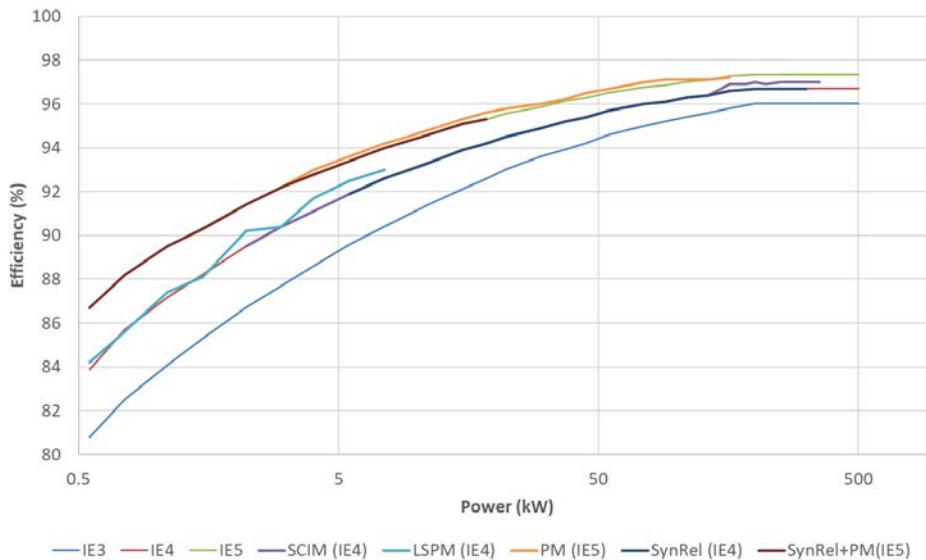

Figure 12 – Efficiency versus power rating of various motor efficiency standards [65].

In 1995, most of the electric motors sold worldwide did not reach efficiency level IE1. Twenty years later, most motors sold were at least at efficiency level IE2.

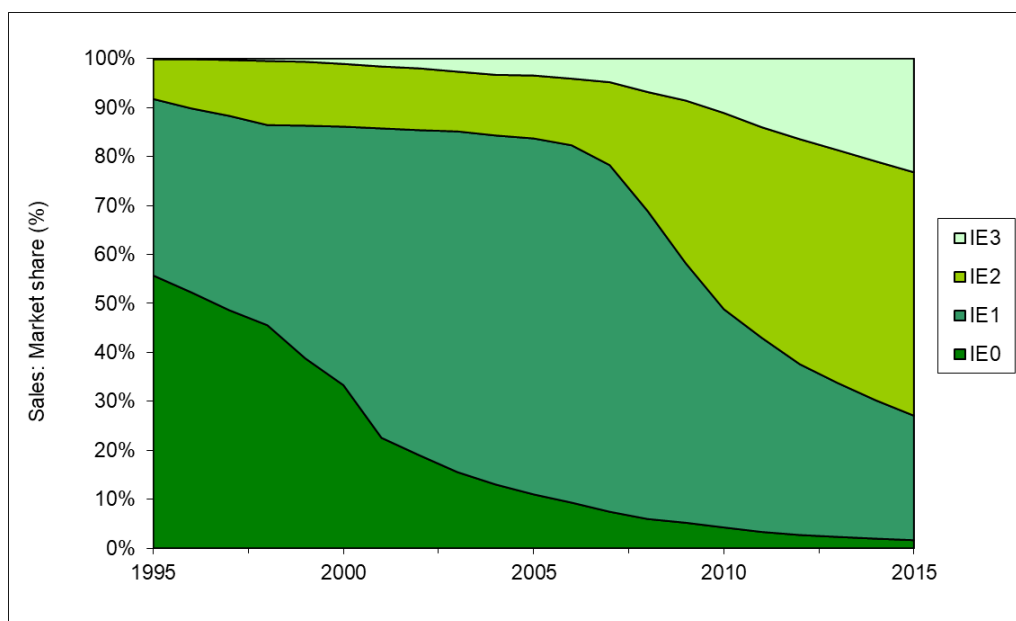

Figure 13 – Evolution of global sales of motors by efficiency class (source: [62]).

However, due to the long service life of motors, the efficiency of the motors in use lags a long way behind sales figures. In 2015, only about 40% of all motors in use around the world reached efficiency level IE2.

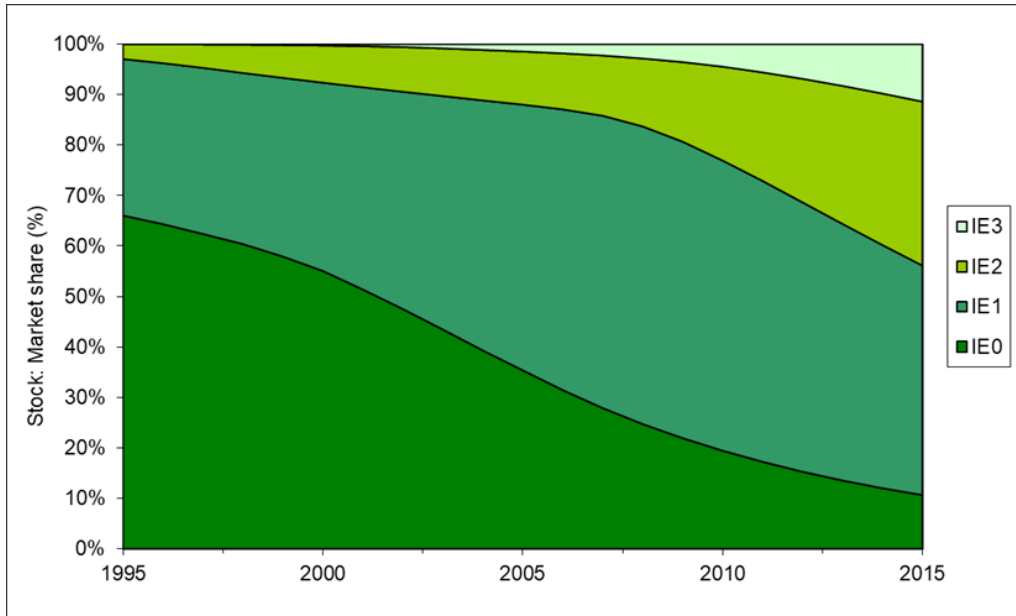

Figure 14 – Evolution of the global stock of motors by efficiency class (source: [62]).

Generally, estimated service life is 10 to 20 years, but a Swiss survey of 17 industrial parks where a total of 3979 motors [63] were in use discovered that 58.4% of the units had exceeded their operating life expectancy (10 to 20 years depending on their size), with some units up to 60 years old. While this survey may not be representative of the whole of Europe, it shows that the supposition that all motors are renewed at least every 20 years does not hold true. Consequently, it will take longer than first thought to raise the overall efficiency of motors in use, unless the motor replacement rhythm is revised. It also illustrates how crucial it is to apply advanced standards now to regulate motors sold today, since they will be locked-in for many years.

The evolution towards more energy efficient motors makes sense from an economic point of view. A major part of the life cycle cost of a motor is the energy cost. As a result, energy efficient motors have a lower life cycle cost than their less efficient counterparts in most cases.

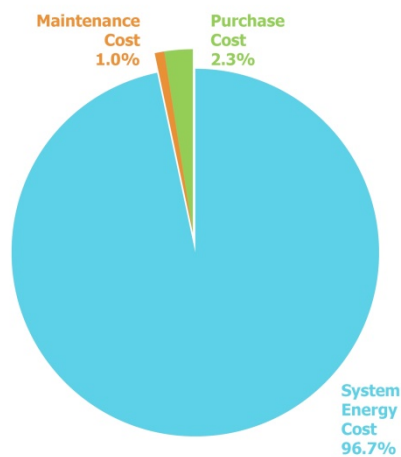

Figure 15 – Life cycle cost of an 11 kW IE3 motor running 4000 hours/year over a 15-year life cycle [64].

How significant this energy cost is depends on the running hours of the motor, the load pattern during those running hours, and the electricity price. It is often a complex task to determine such figures with a high degree of precision. Fortunately, a reasonable estimate will in most cases be adequate for making a sound decision on

which efficiency class is to be preferred from a life cycle cost point of view. The techno-economic optimum typically lies somewhere between IE3 and IE5.

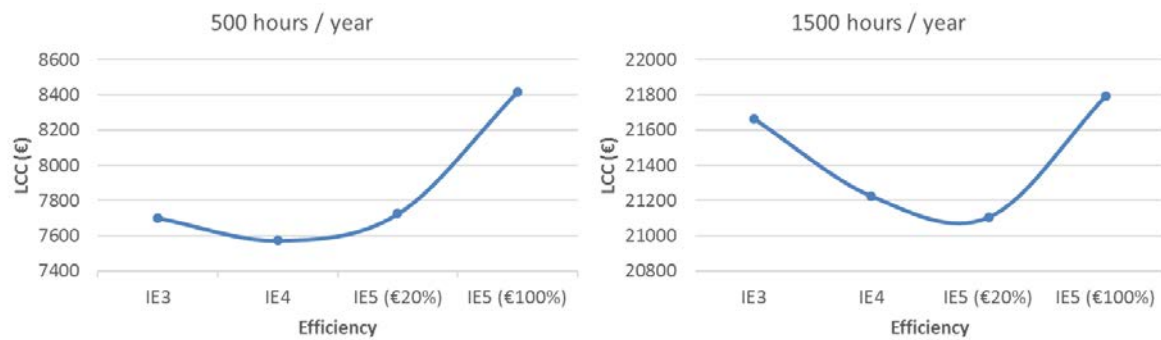

Figure 16 – The relationship between the energy efficiency class and life cycle cost for a 11 kW motor running 15 years for 500 hours (left) or 1500 hours (right) per year, at an electricity cost of 0.119 €/kWh (Source: [65]).

Despite the clear economic advantages, various market barriers have hampered the adoption of energy efficient motors over many years. These barriers to adoption include difficulties arising from the split between investment and operational budgets, lack of investment capital, and institutional and individual resistance to change. The success story described above can mainly be attributed to the introduction of minimum efficiency performance standards (MEPS) in several countries and regions around the world, including the Small Electric Motors Energy Conservation Standards (part of the Energy Policy and Conservation Act) in the USA and EU Regulation No. 640/2009.

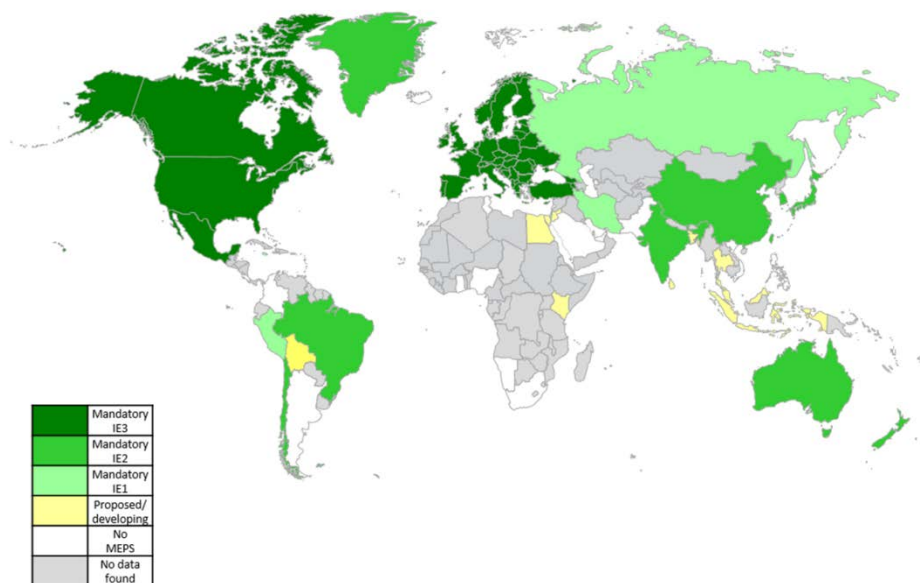

Figure 17 – Minimum efficiency performance standards (MEPS) for electric motors around the world [65].

The impact of the CEMEP/EU Agreement on voluntary labelling of electric motors which ran between 1998 and 2009 was limited. Although it was an important factor in removing motors from the lowest efficiency category (below IE1) from the market, it barely made a dent in the market penetration of high (IE2) and premium (IE3) motors. The latter did not fully emerge until mandatory regulation came into force.

EU REGULATION FOR MOTOR ENERGY EFFICIENCY

EU Regulation (EC) 640/2009 on electric motor efficiency, which came into force in 2009, is an implementing directive forming part of the Ecodesign Framework Directive 2009/125/EC. It is based on the findings of the *Energy-using products (EUP) Lot 11 Motors* study which highlighted the importance of introducing minimum efficiency performance standards (MEPS) for motors.

The Regulation defines MEPS for electric motors of medium size. It involves three phase 50 Hz or 50/60 Hz squirrel cage induction motors with 2 to 6 poles and a rated voltage of up to 1000 V. The motor efficiency is defined as the mechanical power output divided by the electrical power input. The regulation was rolled out in three steps:

- IE2 as the minimum efficiency level for all new motors sold on the EU market from 16 June 2011;
- IE3 as the minimum efficiency level for motors with a rated output of 7.5 – 375 kW from 1 January 2015, except for motors combined with a variable speed drive (VSD), which only need to comply with efficiency level IE2.
- The former regulation was extended to motors with a rated output of 0.75 – 375 kW from 1 January 2017.

Motors that are integrated with their application into a sealed unit (e.g. pumps, fans, gear units and compressors), and whose efficiency cannot be measured independently, do not fall under this regulation. There are some other exceptions, such as for brake motors, explosion-proof motors, and for motors operating under extreme conditions (for example, fully immersed in liquid, in very high or very low temperatures, or at high altitudes).

The regulation was estimated to have an average savings potential of 65.7 TWh/year for the period 2010 to 2020 [66] (rebound effects not taken into account). This corresponds with 29.37 million tonnes of CO_{2eq}/year, calculated using the 2013 figure of 447 gCO_{2eq}/kWh for electricity generation carbon intensity in the EU [3].

EXTENDING REGULATION TO OTHER MOTOR CATEGORIES

EU Regulation 640/2009 addresses approximately 60% of all motor energy consumption in the EU [67]. A new Ecodesign preparatory study (Lot 30: Special Motors) was launched in 2012 to investigate whether the scope should be extended to other motor categories, and whether the exception for motors with VSD could be overturned. For the first time, the efficiency of the actual electronic controllers (VSDs and soft-starters) was also a subject of study.

The following extensions were evaluated:

- Small single- and three-phase motors (120 - 750 W). The IE2 efficiency level was found to be a good minimum for this range. Even though many of the small motors are integrated into the application and consequently not included here, the total energy savings potential as calculated in the LOT 30 preparatory study is still significant.
- Large motors (375 - 1000 kW) of low voltage (< 1000 V) or medium voltage (< 6600 V). The potential energy savings in this category are smaller since most of these motors are already designed for low life cycle cost and because larger motors have inherently higher efficiency.
- Removal of the choice to opt for IE2 if combined with a VSD. See *“Going beyond the component approach”* for the reasoning behind this. IE3 would also become the mandatory efficiency level here.

- Removal of the exception for brake motors and explosion-proof motors. There are no technical impediments for these motors to achieve the same efficiency levels as general-purpose motors.

The additional savings potentials up to 2030 of those extensions can be summarised as follows [68]:

Possible measures	Energy saving (TWh/a, average till 2030)
Small single-phase motors (120 W – 750 W) – IE2	4.6
Small three-phase motors (120 W – 750 W) – IE2	9.9
Large low-voltage motors (375 kW – 1000 kW) – IE3	3.1
Large medium-voltage motors (375 kW – 1000 kW) – IE3	1.1
Removal of option to use IE2 motor where VSD is used	2.7
Adding explosion-proof and brake motors to scope of regulation	0.9

Table 4 – Additional savings potentials of extensions to the existing ecodesign regulation for motors in the EU.

This constitutes a total savings potential of 22.3 TWh/year, or 9.97 million tonnes of CO_{2e}/year.

At the time of writing, *Ecodesign Lot 30* has not yet been transformed into a regulation. The reason for this hesitation is unclear, given the substantial savings potential, the lack of any technical barriers and the net economic savings that are likely to accrue from the proposed regulatory measures.

ENHANCING THE EFFICIENCY LEVEL TO IE4

For medium power motors (0.75 - 375 kW) that have had a MEPS designation of IE3 since 2015, further enhancement of the efficiency level to super premium (IE4) in four or five years from now becomes a realistic goal. At current prices, IE4 motors are already advantageous from a total cost of ownership (TCO) point of view for a wide range of load profiles [65]. With prices expected to fall in the next few years [107], making them mandatory through MEPS for medium-power motors will become sound from both an economic and environmental (carbon emissions) point of view. This would lead to additional energy savings of an estimated 7.9 TWh per year [107].

A similar MEPS level could be set for large power motors (375 - 1000 kW). Even though they have not previously been subject to regulation, they are already being built to higher energy efficiency standards compared to motors of smaller power because of the greater attention to their life cycle cost and because they have inherently higher efficiency due to their size. This makes the IE4 efficiency level easily attainable for this motor category. IE4 MEPS for large power motors is expected to lead to additional savings of 1.4 TWh per year [107].

The total energy savings associated with IE4 MEPS for both motor categories would consequently mount to 9.3 TWh per year, corresponding to a carbon emission saving of 4.16 million tonnes of CO_{2eq} per year.

Without such a regulation, the market penetration of IE4 motors is expected to remain at a fairly low level, similar to what happened during the previous transition between IE2 and IE3 motors. Even though motors of higher efficiency are often economically advantageous, barriers such as their higher purchasing price, compartmentalised budgets and reluctance to change hamper their breakthrough, creating a loss for both the economy and the environment. Without MEPS making IE4 mandatory, their market penetration is expected to follow the pattern in the chart below:

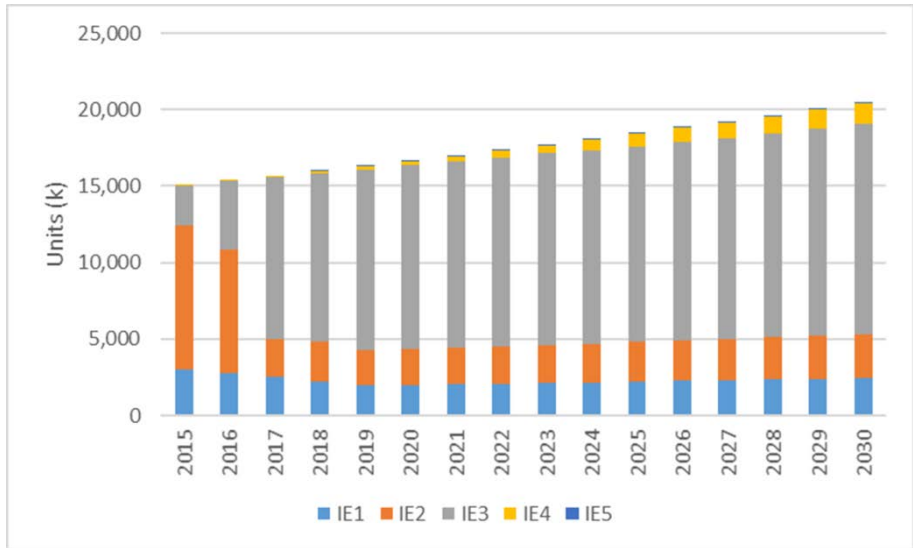

Figure 18 – Expected sales figures for medium power motors without IE4 level MEPS [107].

With IE4 level MEPS, the per unit sales figures for IE4 motors would look like this:

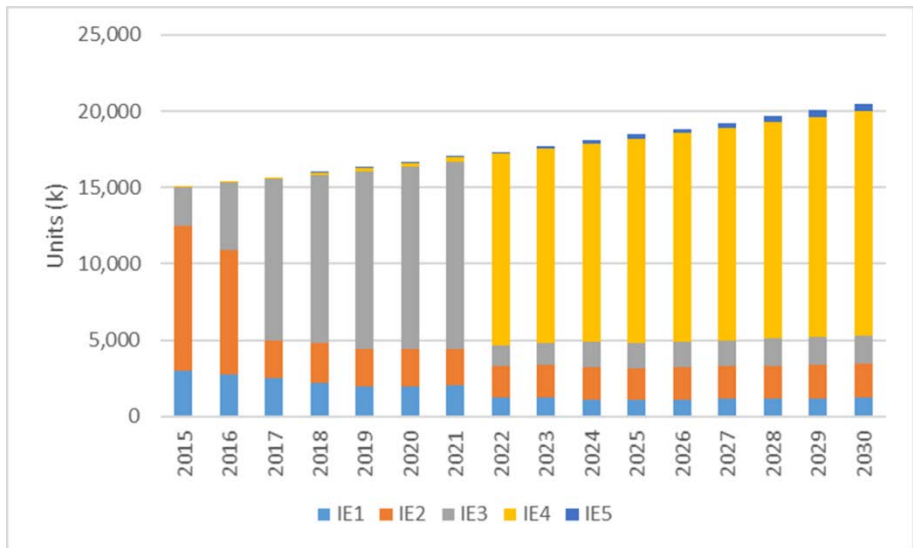

Figure 19 – Expected sales figures for medium power motors if MEPS were to be raised to IE4 level from 2022 [107].

This clearly shows that MEPS are indispensable if IE4 motors are to achieve a general market breakthrough in Europe before 2030.

INCREASING THE IMPACT THROUGH IMPROVED IMPLEMENTATION [69]

The theoretical savings arising from MEPS for electric motors are well known, but the actual savings in the field are more difficult to calculate. There is a **lack of capacity in the EU to check the compliance of electric motors against the prevailing standards**. Market surveillance is a responsibility that is delegated to member states. The only EU countries currently implementing any kind of systematic motor verification tests are Denmark and Germany.

Given the enormous numbers of electric motors sold in the EU (approximately 10 million per year), setting up a system for compliance verification is challenging. Creating sufficient new independent laboratory capacity does not seem realistic or cost-efficient. A system of certification of existing private and university laboratories is probably the better way forward. Ideally, laboratories should be semi-independent entities within the owning companies.

The US system to check compliance with the NEMA Premium motor regulation could serve as a good example. It demonstrates how market surveillance can be effective without the need for independent laboratories to systematically verify every motor. The US system includes the following elements:

- High penalties for manufacturers of non-compliant motors;
- Random compliance testing by independent laboratories;
- Market self-control: any company can take the initiative to verify the compliance of a motor, including a direct market competitor;
- If a motor is reported to be non-compliant, this is verified by an independent laboratory before a penalty is applied to the manufacturer;
- The system could also include a penalty for unfair accusations.

In any case, EU member states should be active in their efforts to verify compliance to ensure that the estimated energy and emission savings potential is actually realised.

INCREASED IMPACT THROUGH THE GROWING NUMBER OF MOTORS IN USE

The impact of any kind of MEPS for electric motors is enhanced by their expected market growth. Conversely, since the number of motors in use is expected to grow substantially, it is even more crucial that they are as energy efficient as possible.

The share of electric motors in energy end-use is expected to grow from the current 9% to a figure around 30% during the energy transition of the next 30 years. A detailed estimation of the rise of motor systems for various market segments is made in the Annex.

GOING BEYOND THE COMPONENT APPROACH

An electric motor does not function alone, it is always part of a bigger system. The motor-driven unit (MDU) consists of the electric motor itself, sometimes controlling equipment such as a soft starter or VSD, supporting mechanical equipment (such as gears, belt, clutch, and brake), sometimes side processes such as a cooling system, and finally the actual application it is driving (perhaps a pump, fan, or compressor). The motor system also includes all other components that could suffer energy losses (including water or air ducts, throttles and valves). This motor system is then subject to a certain load profile.

Clearly, it does not make sense to optimise components if it does not result in improved operating efficiency for the entire system. Optimising the entire system, from the load profile to the torque and speed profiles, is the best way to reduce energy consumption and CO₂ emissions. The energy saving potential of a system approach over and above the savings potential of component efficiency is difficult to estimate but, in any case, it is likely to be substantial.

INTERNATIONAL STANDARDS ON MOTOR SYSTEM AND EXTENDED PRODUCT EFFICIENCY

In March 2017, the international standard IEC 61800-9 (parts 1 and 2) was published with the title *Ecodesign for power drive systems, motor starters, power electronics and their driven applications*. It is heavily based on the European standard EN 50598 which has been in effect since 2014. The standard describes how to verify and classify the energy losses of the entire system (motor, VSD, starter, transmission and application) at both full load and designated part load conditions. If the time-load profile of the application is known or can be

estimated, a weighted addition of the efficiencies at various load conditions results in the energy efficiency index (EEI), which can be used as a benchmark to compare different configurations. [70]

The EU Ecodesign regulation takes the extended product efficiency into account only where it concerns fully integrated motor systems. One example is the recently created LOT 31 for integrated compressor units, for which the regulatory work has started, and for which an impact assessment is expected for the end of 2018 or the first half of 2019. A similar regulation for circulator systems (pump devices used to circulate a fluid in a closed system) will come into effect by 2020. Outlined in Appendix 7 of Ecodesign Lot 11, this is expected to lead to an annual saving of 23 TWh in the EU [71].

MOTORS AND VARIABLE SPEED DRIVES (VSDs)

IEC 61800-9 defines efficiency classes for the system of motor and VSD (called power drive systems or PDS in the standard). IES1 is the reference class, with energy efficiencies listed according to the rated power. If the PDS has at least 20% greater energy losses than the reference, it falls into category IES0. If energy losses are lower than the reference by at least 20%, it is classified as IES2. The IES class is determined at nominal load and nominal speed (100% / 100%). [70]

A common misunderstanding is that the use of a VSD to control the motor will always improve the energy efficiency of the system. This can be the case, but depends on many influencing factors. Looking only at the motor itself and its control system, a system including a VSD will *always* have a lower energy efficiency than a motor with just a soft starter or no control at all. If the system has to operate at partial load, however, this efficiency loss in the motor control can be lower than the loss that would be generated if load control has to be done at the level of the application (e.g. through valves or throttles).

When designing a system, the first concern is to keep the part load situations as infrequent as possible. If operation at part load is necessary, however, this can be accommodated at the motor level through:

- ON/OFF control
- A cascaded system with various smaller motors
- A VSD

An analysis must be carried out for each individual application to assess which of those solutions results in the highest energy efficiency and lowest TCO. A solution with a VSD is estimated to be the most energy efficient option in 40 to 50% of situations.

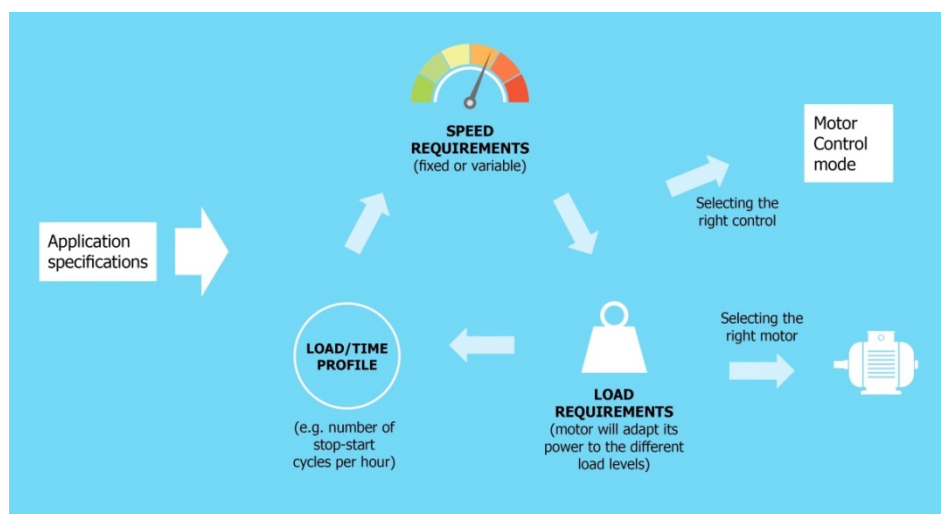

Figure 20 – A system approach to a variable load profile [Source: CAPIEL].

Once the control system has been selected, a corresponding motor can be chosen. To stimulate investment in VSDs, the EU MEPS accepted a lower motor efficiency (IE2 instead of IE3) where a VSD is used. Partly because of this measure, and partly resulting from developments in power electronics, price decreases, and an increased awareness of its benefits, the VSD market has been growing fast in the past 20 years and is predicted to continue to grow in the next few years. As a result, this stimulation measure, which does not make sense from a system efficiency point of view, has been rendered obsolete. The mandatory energy efficiency level for a motor with a VSD should be the same as for any other motor unit.

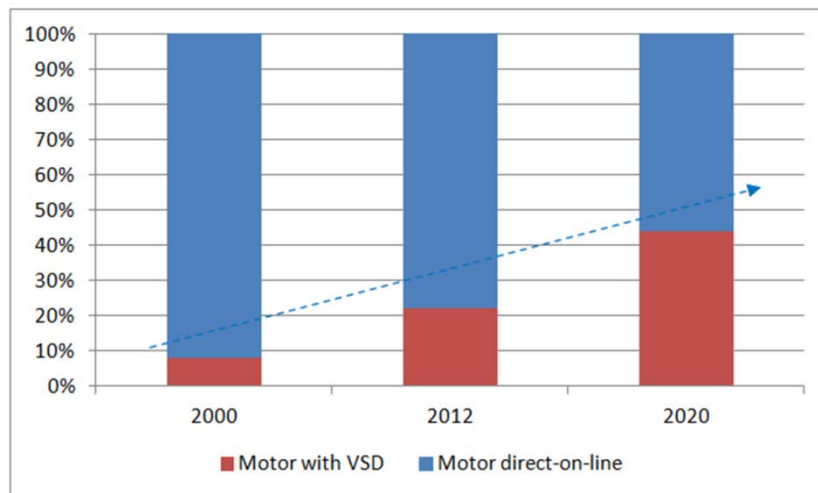

Figure 21 – VSD market penetration growth and forecast [67].

THE EXTENDED PRODUCT APPROACH: MOTOR SYSTEM + TRANSMISSION + APPLICATION

A system approach should be followed to minimise the energy losses in all components, including in both the motor driven unit and the application (for example, a pump or compressor) and all the mechanical connections in between. Given the complexity of such a procedure and the unique character of each application and its load, promoting motor system efficiency is not a straightforward task.

Lot 30 of the EuP preliminary studies wanted to incorporate the notion of system efficiency into its “extended product approach” but admitted the difficulties of translating those principles into a workable regulation. Market surveillance of such a regulation would be particularly challenging. Since each case is different, it is necessary to go on site to assess whether a system is compliant.

One potential path forward is to promote standard IEC 61800-9 more actively, as well as the development of a software tool that can assist in implementing this standard.

Another complementary possibility is to promote motor system efficiency via an Energy Management Systems approach (EnMS).

ENMS

The Energy Management Systems approach (EnMS) was initiated in 2007 by the United Nations for Industrial Development Organization (UNIDO), who convened an expert group meeting (EGM) on the topic [72]. This was picked up by the International Standardization Organization (ISO), leading to the development of the new energy management standard ISO 50001, published in 2011 [73].

The purpose of an EnMS is to provide guidance for industrial facilities to integrate energy efficiency into their management practices, including the fine-tuning of production processes and the improvement of industrial

systems [74]. The EnMS is formalized by the PLAN-DO-CHECK-ACT (PDCA) approach, as illustrated in the following graphic:

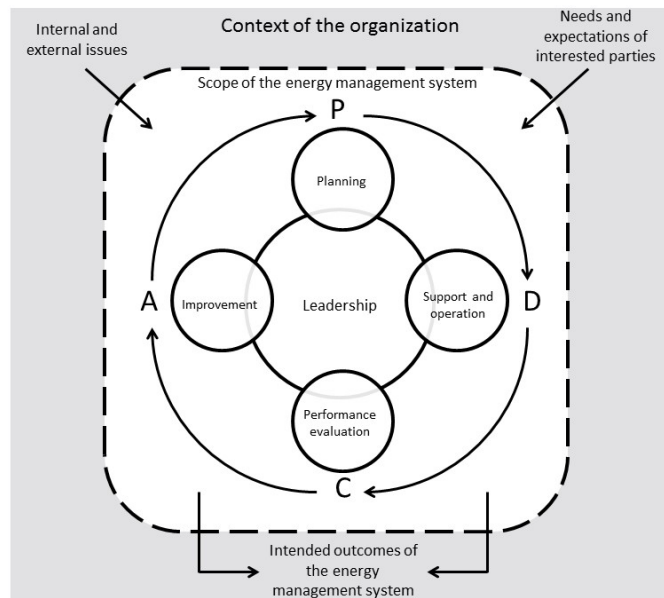

Figure 22 – Plan-Do-Check-Act Cycle of ISO 50001 [73].

ADVANTAGES OF ENMS FOR OPTIMISING MOTORS SYSTEMS

EnMS stimulates the industry to adopt systemic thinking. It prescribes that energy using systems, including motor systems, must be controlled and maintained in a structured manner, adopting practices that see those systems in an integrated way, and no longer as individualised components.

In addition, continuous monitoring of energy consumption can lead to adjustments and optimisations based on the particular characteristics of the system.

SELECTING THE SIGNIFICANT ENERGY USES (SEUs)

Within EnMS (ISO 50001), emphasis can be placed on motor system efficiency through the selection of significant energy uses (SEUs).

During the PLAN phase of the PDCA approach, an energy review must be carried out. Based on the results of this review, the systems responsible for most of the energy use are identified. These SEUs will then become the focus of the action plan (DO phase).

In the new edition of ISO 50001 (2018), motors are explicitly mentioned in the description of SEUs: “SEUs may be defined depending on the needs of the organization such as by facility (e.g. warehouse, factory, office), by process or system (e.g. lighting, steam, transport, electrolysis, motor-driven) or equipment (e.g. motor, boiler). Once identified, the management and control of SEUs is an integral part of the EnMS”.

ENMS IMPLEMENTATION GUIDELINES

The guidelines of ISO 50001 are generic (technology and system independent), but system-specific guidelines can be developed which support EnMS implementation.

In Brazil, such guidelines have been developed for motor system optimisation under EnMS, the first initiative of its kind. It includes specific considerations about motor systems in implementing ISO 50001, as well as a series of examples of motor system optimisation under EnMS.

It would be useful to develop an international version of these guidelines, which could then be formalised into an international standard.

HEAT PUMP SYSTEM EFFICIENCY

The energy efficiency of the circulating pumps incorporated within heat pumps fall under the new EU Ecodesign regulation which will come into effect by 2020 (Appendix 7 of Lot 11).

Heat pump compressors, however, are excluded from EU Ecodesign Regulation LOT 31, since it does not apply to refrigerant and heating circuit compressors. Heat pump efficiency is regulated instead under EU EcoDesign Regulation 813/2013 (space heaters and combination heaters), which is not very exigent. This Regulation prescribes that from 26 September 2017 onwards, heat pump space heaters and heat pump combination heaters (with the exception of low-temperature heat pumps) must have a seasonal space heating energy efficiency of at least 110%. Low-temperature heat pumps must have a seasonal space heating energy efficiency of at least 125% [75].

Apart from these EcoDesign MEPS, an indirect incentive to drive up heat pump efficiency comes from the Energy Performance of Buildings Directive (EPBD). Its gradual evolution towards imposing nearly-zero-energy standards stimulates the sector to minimise the remaining electricity consumption of heat pumps. An evaluation of heat pump performance over different projects executed by the Fraunhofer ISE in Germany revealed that the top SPF of geothermal heat pumps increased from 4.0 to 5.4 and the top SPF of air-water heat pumps from 3.1 to 4.2 over the past 12 years. These high efficiencies can only be achieved if the energy efficiency of all components, including the compressor drive, is optimised.

3. ELECTRIC MOTORS AND THE FLEXIBILITY CHALLENGE

KEY MESSAGES

Electricity should not only be used as efficiently as possible (see previous chapter), its consumption should also be shifted as much as possible to moments of abundant production – a constraint that is gaining in importance with the growth of variable renewable energy sources.

Some motor-driven end-use applications have a certain degree of flexibility as to when the electricity is consumed. Examples include:

- Building HVAC: well insulated rooms that need heating, cooling or ventilation represent a buffer capacity on their own;
- Water management: driven primarily by pump systems, water management, purification and desalination systems tend to have substantial storage capacities and great potential for flexibility;
- Industrial process plants: some types of industrial process plants are adapting their production to demand forecasts and material prices. By adding extra storage capacity, this flexibility could also be used for demand response.

A transparent demand response market model is needed where all parties benefit.

Some aspects require further development and harmonisation across the EU:

- **A standardised two-way communication channel** between grid operators and end-users should be introduced. Based on this, the technology of load interruptibility can be developed further.
- **Market access:** the reserve and balancing markets (FCR and aFRR) should be opened up to industrial electricity consumers and to aggregating companies in all EU countries, with a guarantee of fair technical conditions. For wholesale electricity markets (day-ahead and intraday), a more direct and less complicated way to participate should be available to SMEs and independent aggregators.
- **Communication about network constraints:** network operators should manage the network in an active and open manner, communicating openly about the network constraints they are facing, and giving industrial consumers the opportunity to participate in local network services.
- **More accurate demand forecasting:** potential load reductions through demand response should be incorporated in electricity demand forecasts.
- **Stop discouraging self-generation for on-site variable renewable energy (VRE).** Net-metering policies which serve to reduce the economic viability of self-generation should be abandoned.

THE FLEXIBILITY CHALLENGE

The grid operators of the future will need to adjust the ups and downs of variable renewable generation to prevent price volatility and keep grid stability. Part of the solution could be the reinforcement of electricity interconnections between them so that more energy can be transferred from regions with abundant production to regions with a production shortage. Another part of the solution is enhanced flexibility, which could come from the supply side, from the demand side, or from grid-connected storage systems. Supply-side flexibility is often expensive and carbon intensive. Grid-connected storage systems and demand response (DR) are useful additions to solve the flexibility issue.

In demand response we mainly see a role for industrial electricity consumers and large buildings, at least in the short or medium term. The concept has become increasingly familiar to companies with energy-intensive processes. DR software tools that allow companies to manage their power demand in response to market or weather signals are already available on the market. Nevertheless, for the industrial DR market to fully take off, a few barriers still need to be removed.

Among residential electricity consumers, the potential for flexibility is more difficult to estimate and the barriers to installing smart meters and participating in DR are greater. In most countries and regions, the issue of privacy and the perceived loss of freedom stand in the way of large scale roll-out of residential DR. This could change in the long term as people become more familiar with the concept and aggregators develop products that give sufficient benefit to residential consumers.

DR IN EUROPE TODAY

Until recently, reserve products and balancing activities were the domain of power generators who were often obliged by law to offer these kinds of services. In recent years, electricity trading platforms and balancing markets have been partially opened to industrial energy consumers who wished to valorise their flexibility and offer DR. These systems and markets differ substantially from one European country to another, but a slow convergence process between the countries is ongoing [76].

The following basic mechanisms can be distinguished:

Market mechanisms

The most common electricity markets to valorise flexibility are the day-ahead and intraday markets.

In the day-ahead market, electricity is bought and sold through bids. Minimum prices can be set by the seller and maximum prices by the buyer. An industrial consumer could for example make an arrangement whereby, in the event that electricity prices rise above a certain level, they will address its flexibility potential and no longer consume their initially planned share of electricity.

The intraday market is based on continuous trading and involves much lower quantities of energy. Not all industrial consumers have access to European intraday markets at present – directly or via aggregators – which is one of the barriers to be addressed [76].

Bilateral deals

Both standard and non-standard trading products can be exchanged through bilateral contracts. This is currently mostly used between power generation companies, for example a renewable energy supplier and a utility company owning stand-by gas-fired power plants. However, there is no reason why industrial consumers could not be more involved in such contracts in the future, for instance a renewable energy supplier buying flexibility from an industrial consumer.

TSO interactions

To be able to balance the grid at any moment, the transmission system operator (TSO) buys reserves on the balancing market. A typical breakdown of the reserve products in European countries is the following:

- Frequency Containment Reserve (FCR) which requires automatic and very fast response (reaction time <30 seconds);
- Automatic Frequency Restoration Reserve (aFRR) which requires a fast response time (30 seconds – 15 minutes);
- Manual Frequency Restoration Reserves (mFRR) and Replacement Reserves (RR) which include slower reserve products with varying reaction times and generally longer activation times.

In most EU countries – though not in all – electricity consumers can participate in the mFRR market. The aFRR and FCR markets have more stringent requirements and in some EU countries, participation by consumers is not permitted (e.g. Spain). Market design reforms should systematically open up the aFRR and even FCR markets to the participation of consumers. [76]

Note that at present, the aFRR and mFRR reserve products are used only sporadically. To accommodate a future power system with higher degrees of intermittent renewables, more continuous balancing will be required, both intraday and across longer time periods.

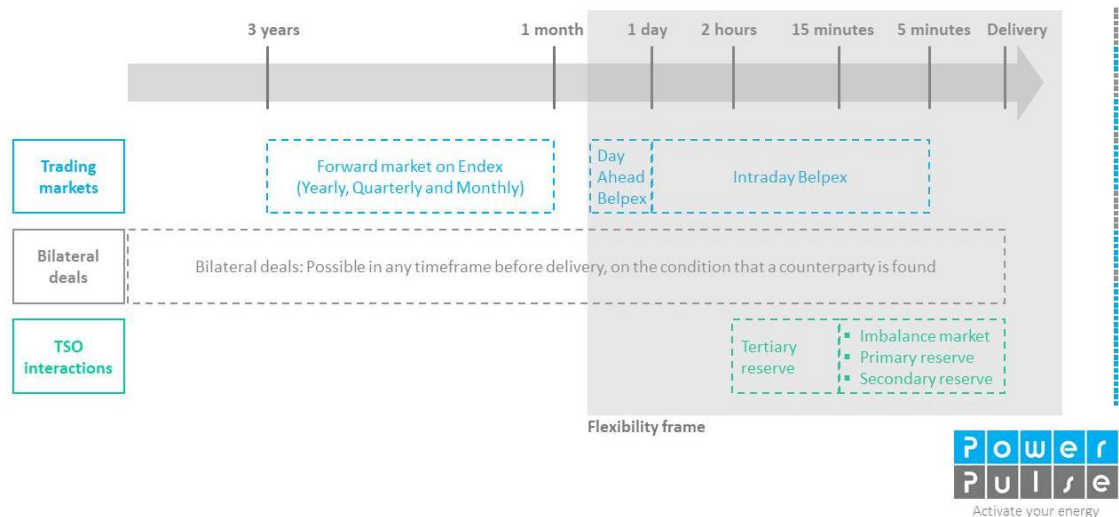

Figure 23 – How to source electricity and valorise flexibility – an example from Belgium [76].

Aggregators

Aggregators build up a portfolio of flexibility from several end-users with different characteristics. They offer this in an aggregated way on the reserve or balancing markets and receive a share of the resulting revenues. Thanks to aggregators, smaller electricity consumers can gain access to the flexibility markets.

MOTOR UNITS OFFERING FLEXIBILITY

Electric motors can react to electricity prices or DR signals by starting up and shutting down, or through speed variation. Motors have the advantage that they are easy to control remotely.

The time for a motor to go from zero to full load is typically between 1 second and 1 minute. This means that participation in the FCR market (reaction time <30s) is only possible in some cases. Participation in the aFRR market (reaction time 30s - 15 minutes) should be possible for most motor units as long as the load can be

shut down and restarted safely. At present, most of the flexibility valorised by electricity users in Europe is at the level of mFRR (reaction time > 15 minutes) and in intraday and the day-ahead trading markets. [76]

It should be noted that there is a potential power quality issue relating to large scale remote control of motor units, but this issue can be resolved. If a large number of motors start up simultaneously in response to a price or other DR signal, it is highly recommended that they be equipped with a soft starter or VSD to avoid an excessive current surge on the grid.

MOTOR APPLICATIONS OFFERING FLEXIBILITY

Apart from the above considerations, flexibility is not inherent to the electric motor unit itself, but to the application where it is used. Whether an application is suitable to offer flexibility depends on the following criteria [77 and 76]:

- **Activation effort** and cost required to start-up or shut-down a process;
- **Presence of storage or buffer capacity** making it possible to shift the energy consumption in time. This can take different forms, including heated or cooled rooms, and gases or liquids under pressure;
- **Reaction time:** the time it takes for a process to ramp-up or ramp-down after a signal is given;
- **Potential duration and frequency:** the maximum length of time during which flexibility can be activated, and the number of times a given flexibility can be activated in a period of time;
- **Part-load and over-load abilities:** the technical ability of a process to operate below or above nominal operation levels;
- **Synchronicity:** the ability of upstream and downstream processes to automatically adapt to load variations in the core process.

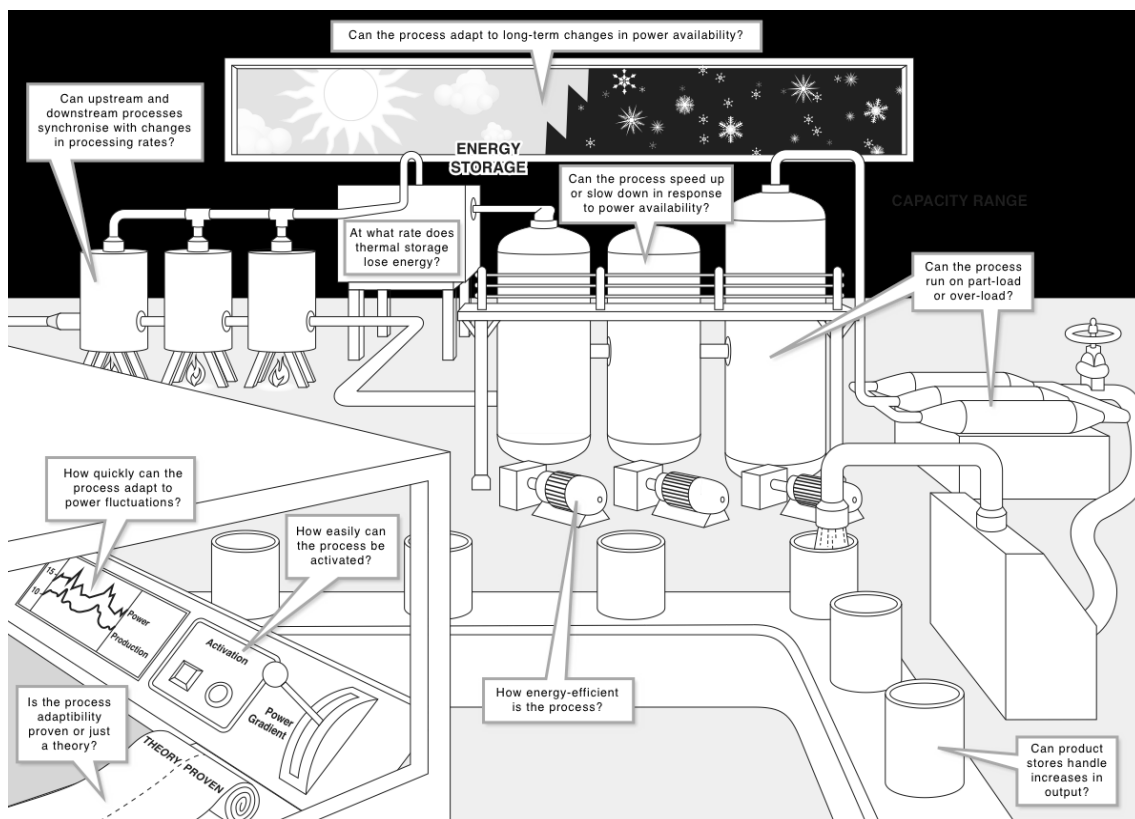

Figure 24 – Example of a flexibility checklist applied to an industrial site [77].

In practice, most of the motor driven applications that are suitable for offering flexibility are driven by pump, fan or compressor systems. Where fluids or gases are involved, it is likely that a storage or buffer capacity is available and that running the system at part-load is possible. Often those systems are already adapted to function with some flexibility. And even though their storage capacity is there for a reason, the requirements it was installed for and the requirements for demand response do not always coincide, meaning that the storage capacity can be used for both purposes. In some cases, it can be economically justifiable to build extra storage capacity that will be paid back by the revenues of demand response.

That said, not all industrial production sites have the characteristics to offer demand response. Shifting a production process in time to react to momentary electricity prices is not an option if there is any risk of impairing the quantity or quality of the product or of the process. For instance, the consequences of running at part-load are less clear where processing and handling of solid goods is concerned. Moreover, changes in the operational scheme and impact on personnel planning and costs, as well as the lack of automated control systems to monitor and adjust the industrial processes can prove to be difficult barriers to overcome. [78]

Electric vehicle (EV) batteries represent an interesting opportunity for demand response, since most cars are parked most of the time. Vehicle-to-grid (V2G) technology groups a large number of EVs together to behave like a virtual power plant and supply a variety of system services to the grid. However, this is not strictly a motor-driven DR, since the response is not made by starting up or shutting down the motor itself.

The following are three examples of motor-driven processes with great potential for participating in DR.

MOTOR DRIVEN SYSTEM FLEXIBILITY IN SPACE HVAC

[77]

If well insulated, a room that needs to be heated, cooled or ventilated is a buffer in itself. The moments at which the heating or cooling device is set to work can be easily shifted without causing the temperature to drop or rise beyond its thresholds. This makes HVAC systems very well suited to participation in DR. They are driven by compressors (heat pump), fans (ventilation) or pumps connected to a boiler (traditional central heating). Their storage capacity can be further increased by adding a storage vessel for the hot/cold fluid/gas in the circuit, but where there is hot sanitary water production, such a storage vessel is already present.

The activation effort and reaction time of the HVAC compressor, fan or pump systems is generally low, and the machinery can be activated (on or off) often. However, where the buffer is the room itself, the maximum duration of the DR action cannot be too long or the temperature will rise above or drop below the threshold value, or the air quality will deteriorate. If the motor systems can operate at variable speeds, this creates natural part-load ability. If several motor systems operate together in one heating, cooling or ventilation system, part-load ability can also come from activating only some of them.

MOTOR DRIVEN SYSTEM FLEXIBILITY IN INDUSTRIAL PROCESS PLANTS

[77]

Some types of industrial process plants are well suited for offering flexible energy consumption. One example is chlorine-alkali production: a continuous process that consumes energy through its pump systems and electrolysis cells. It already operates variably, adapting its process capacity to demand as well as to the prices of chlorine, caustic soda and hydrogen. For this reason, the production installations contain storage capacity and are designed to operate at part-load and to some extent also in overload. The activation effort is low, but reaction times for DR can be slow (> 15 minutes). The existing storage capacity will have to be shared with market requirements, limiting its potential for DR. Therefore, to profit more from the inherently flexible system, it can be a good idea to build extra storage capacity if the investment can be gained back through DR revenues.

MOTOR DRIVEN SYSTEM FLEXIBILITY IN WATER MANAGEMENT SYSTEMS

[77]

Population increase and the decrease in available fresh water sources creates a growing need for water purification and desalination in many regions of the world. Water management is also a growing concern in many parts of Europe. With this need for water management systems there is also an opportunity: they could become an extensive source of DR for the electricity grid. Driven primarily by pump systems, water management, purification and desalination score high on nearly all the flexibility criteria. It has a large built-in storage capacity, part-load and over-load ability, short reaction times and a low activation effort. The only drawbacks are that water management systems are not always easy to control via external signals, and that water supply is so vital to our society that participation in DR must not increase the risk of water shortages. Despite these considerations, water management can be considered particularly suitable for both short term and long term DR.

FLEXIBILITY BARRIERS AND POLICY REQUIREMENTS

Despite the increasing demand for flexibility in grid management and the substantial potential for industrial DR in Europe, the market for DR has still not fully taken off. There is a need for a market model where all parties can benefit. The assessment of a series of case studies on industrial demand-side flexibility in various EU countries showed that the long pay-back time of flexibility investment is a major barrier to the development of DR in industry [78]. This means that current business models are not yet sufficiently tuned to the needs of industry. The following factors can accelerate the development of this market [79, 80].

A HOLISTIC AND HARMONISED REGULATORY APPROACH

The extent and nature of policy and regulation to promote DR differs greatly between EU countries. There is an urgent need for harmonisation, especially since multi-site international industrial companies are major candidates for DR participation. A system-wide regulatory approach is to be preferred. Policies should interact positively with other regulatory aims and actions and should focus on the benefits to all parties involved.

STANDARDISED TWO-WAY COMMUNICATION

A standardised two-way communication channel between grid operators and end-users should be introduced. Based on this, the technology of load interruptibility can be developed further, operating according to a business model that is advantageous for all parties.

PROVIDE MARKET ACCESS

The reserve and balancing markets (FCR and aFRR) should be opened up to industrial electricity consumers and to aggregating companies. This is currently not the case in most EU countries. Fair technical conditions should be guaranteed for demand-side access to all these markets. [81]

For wholesale electricity markets (day-ahead and intraday), a more direct and less complicated way to participate should be available to SMEs and independent aggregators, who currently often have to negotiate various contracts (with TSO, DSO, balance responsible party (BRP) and consumer) for a single flexibility offering.

PROMOTE ACTIVE GRID MANAGEMENT

Grid operators should manage the grid in an active and open manner, communicating openly about the constraints they are facing, and giving industrial consumers the opportunity to participate in local grid services [81]. A positive example is that of the Australian state of New South Wales, where its *Demand Management Code of Practice* mandates an annual public review identifying (future) constraints [82]. This makes it possible for external parties to propose options for relieving those constraints. DR opportunities can be realised

through standard offers for short-term grid constraints and through negotiable offers for larger-scale DR projects.

MORE ACCURATE DEMAND FORECASTING

Electricity demand forecasts should recognise potential DR contributions. Forecasts should include substantial load reductions that work at specific locations (to relieve congestion) or at particular times (to relieve peak loads).

STOP DISCOURAGING SELF-GENERATION FOR ON-SITE VARIABLE RENEWABLE ENERGY (VRE)

Locating wind or PV power generation on industrial premises can be an excellent incentive for an industrial company to investigate and maximise the flexibility of their electricity demand, since maximising self-consumption can reduce transmission and distribution costs.

To stimulate this, the net-metering policies (as introduced in some EU countries) which serve to reduce the economic viability of self-generation should be abandoned. These policies were instigated to ensure that grid operators do not lose too much of their revenues due to renewable energy self-consumption. However, this revenue can also be assured through other financing mechanisms that do not hamper the harvesting of demand-side flexibility via on-site RES.

4. SUSTAINABLE MATERIAL USE –MOTORS IN THE CIRCULAR ECONOMY

KEY MESSAGES

The energy transition can only be sustainable if material use is taken into account. With the Circular Economy Package the European Commission has also come to this conclusion.

The expected increase in the number of motors required during the energy transition leads us to the question **whether those motors have the potential to be part of the circular economy.**

If motors consist primarily of copper, steel and aluminium, their depletion potential remains limited and their level of recyclability high. Motors have been rewound and recycled for decades.

Permanent magnet synchronous motors (PMSM) contain various rare-earth metals that appear on the EU list of critical raw materials and are therefore not recommended to become a major part of the solution for emerging mass markets. **Research & Innovation support should focus on the development of rare-earth-free drives.**

Design for Recycling (DfR) considers the technical and economic effort that is required to recuperate as much material as possible during repair and overhaul and at the end-of-life of the product. DfR for electric motors and other products can be stimulated by:

- Providing the buyers of electric motors with information on recyclability, for example through a Design for Recycling label;
- Set DfR as a criterion in public procurement;
- Stimulate the market for recycled metals through centralised metal databases.

THE ENERGY TRANSITION AND THE CIRCULAR ECONOMY

The energy transition is focused on the decarbonisation of the economy to mitigate climate change. However, to create a truly renewable and sustainable energy system, the mineral resources that are used for this transition need to be considered too. In general, green energy technologies place greater demand on minerals than conventional energy technologies. The energy transition will only be sustainable if those minerals can be incorporated into a circular economy that anticipates future mineral scarcity. In a circular economy, end-of-life waste is minimized by creating a “grave to cradle” path to complement the traditional “cradle to grave” path. The global circular economy has two sides: the biochemical and the mineral:

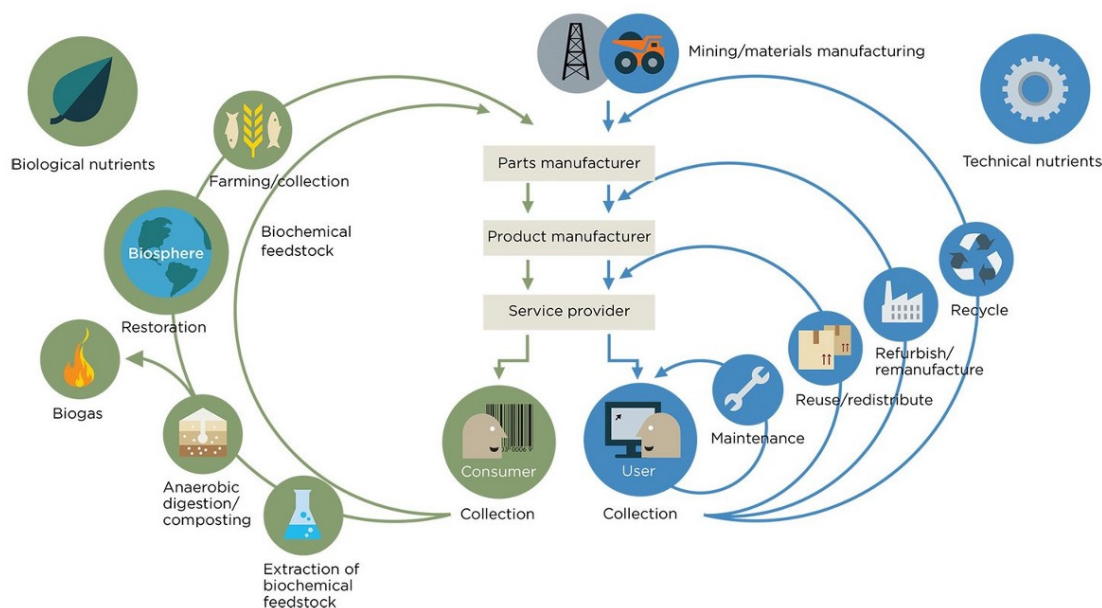

Figure 25 – Circular economy for renewable and non-renewable resources (reproduced with permission. Copyright 2013 Ellen Macarthur Foundation) [83]

In relation to minerals (right side of the diagram), a first priority is to optimise maintenance actions with the aim of extending the useful life of products and materials. Finding efficient ways to re-use and refurbish products can serve a similar goal.

Eventually, however, the useful life will come to an end. A crucial aspect of the circular economy is the recovery of scrap at the end-of-life of a product, as well as its preparation for re-use. The success of the circular economy depends largely on the efficiency of the methods used to achieve this. Equally important is at what stage of the production process the recycled material can be re-used, and how. Are there any losses involved in putting a recycled metal to use compared to that same metal being produced from ores? How much energy is still required to manufacture the end product, and what is the maximum share of recycled material that can be used in the production process?

The EU has been developing a growing regulatory framework in relation to the circular economy beginning with the adoption of the Circular Economy Package by the European Commission on 2 December 2015. The package includes legislative proposals on waste, with long-term targets to reduce landfill and increase recycling and re-use. It also includes an action plan to support the circular economy at each step of the value chain – production, usage, repair, waste management, and re-use as secondary raw material [84]. The regulatory package will lead to exacting end-of-life requirements and strengthened systems of material management.

MOTORS IN THE CIRCULAR ECONOMY

In the introductory chapter we explained that the growing role of electricity in the energy system will lead to a sharp increase in the use of electric motors. In the Annex we estimate that the number of motors in use in the EU will grow by an average of 6 million units per year between the present day and 2040. Currently, electric vehicles and heat pumps mainly use AC induction motors (with aluminium or copper rotors) or permanent magnet synchronous motors (PMSM), and less frequently synchronous wound field or synchronous reluctance motors. However, it is difficult to predict how the motor markets will evolve over the medium and longer term, as the promise of an EV mass market triggers investment in motors Research & Innovation.

MOTOR MAINTENANCE AND REFURBISHMENT

[85]

Maintenance, re-use and refurbishment must be given priority over replacement as part of the circular economy concept. An important consideration, however, is that such prolongation of useful life could slow down the adoption of new models with a higher energy efficiency. In the case of motors, for instance, repairing damaged or faulty IE2 motors could block the market for models with IE3 or IE4 efficiency levels.

In any case, if an effort is made to extend the useful life of an electric motor, care should be taken to at least maintain the existing efficiency level and to avoid compromising its reliability. Proper predictive maintenance based on condition monitoring can be a good base to work from.

Effective refurbishment of electric motors includes the replacement of bearings, which are responsible for 51% of motor failures. A combination of monitoring and planned bearing changes can double or even triple the life of the motor. Moreover, worn bearings constitute high-grade steel scrap that can be completely reprocessed.

Another repair that can extend the useful life of a motor is rewinding the stator, responsible for 16% of motor failures. Stator rewinds can be an effective way to double or triple motor life if they are carried out professionally. The material replaced during such a rewind is high grade copper and insulation. The copper is easy to separate and can be recycled without downgrading.

A new international standard defining the circular economy requirements for electric motors is scheduled to be published at the end of 2018 (IEC 60034 – Part 23:2018, Rotating Electrical Machines: Repair, Overhaul and Reclamation). The standard will ensure that repaired machines meet their original rated performance figures and satisfy the requirements of the circular economy.

The electric motor repair industry in 2016 was worth €4.4 billion. This is more than one third of the entire motor sales market in the EU and is mainly accounted for by local and highly skilled jobs. A longer useful life for motors resulting from proper maintenance and refurbishment is therefore not expected to result in any net economic loss for the EU.

THE MOTOR BILL-OF-MATERIAL

The following chart represents a typical bill-of-materials for aluminium cage IE3 induction motors with power ratings of 1.1, 11 and 110 kW [107].

Materials	Motor Rated Power					
	1,1 kW		11 kW		110 kW	
Electrical steel (kg/kW)	11.00	52.36%	6.36	49.02%	4.18	47.18%
Other steel (kg/kW)	1.68	8.01%	1.05	8.12%	0.73	8.21%
Cast iron (kg/kW)	4.55	21.64%	3.73	28.71%	3.00	33.85%
Aluminium (kg/kW)	0.75	3.59%	0.40	3.12%	0.22	2.48%
Copper windings (kg/kW)	2.55	12.12%	1.25	9.59%	0.65	7.34%
Copper leads (kg/kW)	0.03	0.15%	0.02	0.12%	0.01	0.15%
Insulation material (kg/kW)	0.05	0.24%	0.02	0.15%	0.01	0.11%
Impregnation resin (kg/kW)	0.30	1.43%	0.10	0.77%	0.05	0.56%
Paint (kg/kW)	0.10	0.48%	0.05	0.39%	0.01	0.11%
Total (kg/kW)	21.0		13.0		8.86	

Table 5 – Typical bill-of-materials for aluminium cage IE3 induction motors [107].

The largest share of the motor consists of electrical steel, while there are substantial quantities of cast iron and copper, and a small quantity of aluminium. Where the motor has a copper rotor, there is (almost) no aluminium present and the copper content can go up to 20% of the motor weight. [86]

Permanent magnet motors also contain other metals. Most make use of neodymium magnets (also called NIB or NdFeB magnets). These contain – in addition to iron and boron – the rare-earth metals *neodymium* for power density (typically 31%), *dysprosium* to raise the coercivity (typically 5.5%), a small quantity of *praseodymium* for strength and durability, and small amounts of *terbium*. [87]

The following is a brief outline of the circular economy potential of these metals.

COPPER IN THE CIRCULAR ECONOMY

One of the major advantages of copper is its high degree of recyclability. The pure copper that is used for most electrical conductors becomes high grade scrap at end of life, which means that it can be recycled without downgrading. Its purity makes it possible to use it as a source material for the final stage of the copper production process, saving 80-90% of the energy required for copper production starting from ore [88]. Even if the copper scrap has a lower purity, recycling is still possible (unlike many other metals). Alloying elements and impurities can be removed relatively easily during the copper recycling process.

Because of its high degree of recyclability, the copper used in electric motors is not lost and can be seen as a copper reserve of its own, part of the so-called “urban mine”. Since it can re-enter the production process at a late stage, it can be regarded as having lower entropy than the reserves in the copper ore in the earth’s crust.

The EU is a world leader in copper recycling. In 2015, 61% of European copper at end-of-life was recycled, while copper scrap made up 47% of the source material for the production of new copper (see Figure 26). The disparity between these figures can be explained by the fact that more new copper is produced than the quantities of copper currently nearing the end of its life cycle.

This disparity will only increase because of the growing need for copper during the energy transition. Primary metal production (mining of copper ore) can fill the gap between the secondary material becoming available and total demand [89]. This does not pose an availability problem, since copper reserves and resources are abundant enough to meet the projected growth in demand.

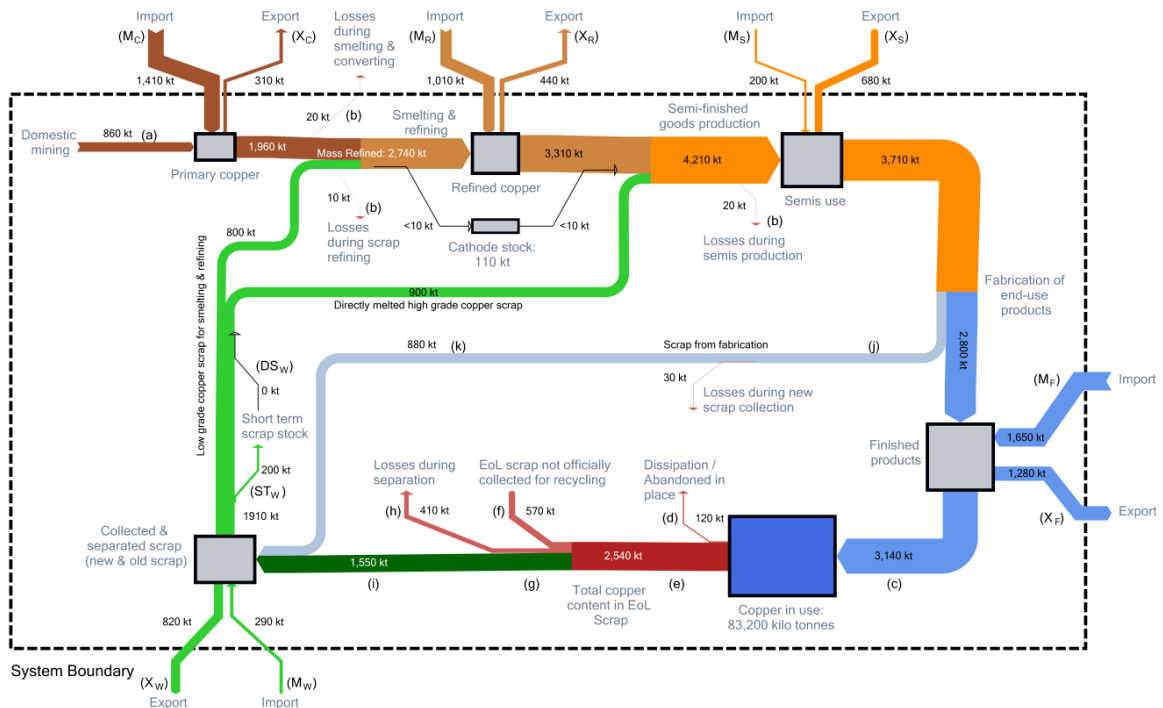

Figure 26 – Copper stocks and flows in the EU-28 in 2015 (© International Copper Alliance & Fraunhofer ISI).

Since 1950 there has always been, on average, 40 years of copper reserves and 200 years of copper resources available around the world. This has been the case because explorations of new deposits, driven by short term supply limitations, have been keeping up with the demand for copper (US Geological Survey). According to the latest data (USGS, 2013), known reserves of copper are around 680 million tonnes, and copper resources are estimated to exceed 3,000 million tonnes (USGS, 2013). The latter includes undiscovered deposits predicted from preliminary geological surveys but excludes the vast copper deposits found in deep sea nodules and submarine sulphides. Copper reserves are sufficiently widespread to avoid geo-political concerns.

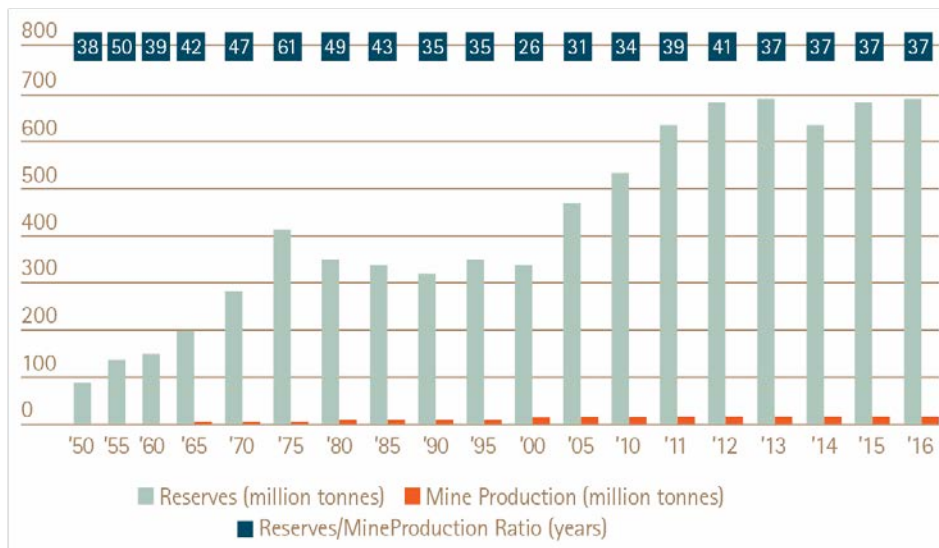

Figure 27 – Historical copper reserves versus copper annual production in million tonnes (USGS 2014).

ALUMINIUM IN THE CIRCULAR ECONOMY

About 8% of the Earth's crust is aluminium, making it the most abundant metal on the planet.

Aluminium can be recycled if the scrap is pure and not contaminated by other elements. If this is the case, the metal can be recycled repeatedly without loss of its properties. Otherwise, dissolved contaminants must be removed or diluted using pure aluminium. Aluminium production from recycled material saves about 95% of the energy required for primary aluminium production, avoiding the corresponding greenhouse gas emissions as well as other types of emissions. All the aluminium collected as scrap is currently taken back by the industry. Global aluminium recycling rates are high, around 90 % for transport and construction applications and about 60 % for beverage cans. [90, p. 110]

STEEL IN THE CIRCULAR ECONOMY

Steel consists mainly of iron, which is also an abundant metal (5% of the earth's crust by weight) [90, p. 268].

Re-use and recycling have a long tradition in the steel industry. Among other uses, process gases from blast furnaces provide heat for coking plants and rolling mill ovens. Together with the process gases from basic oxygen furnaces, they are also used to generate electricity in power plants. [91]

Recycling and primary steel production go together. The introduction of recycled material is routine in most steel production process routes [90, p. 185].

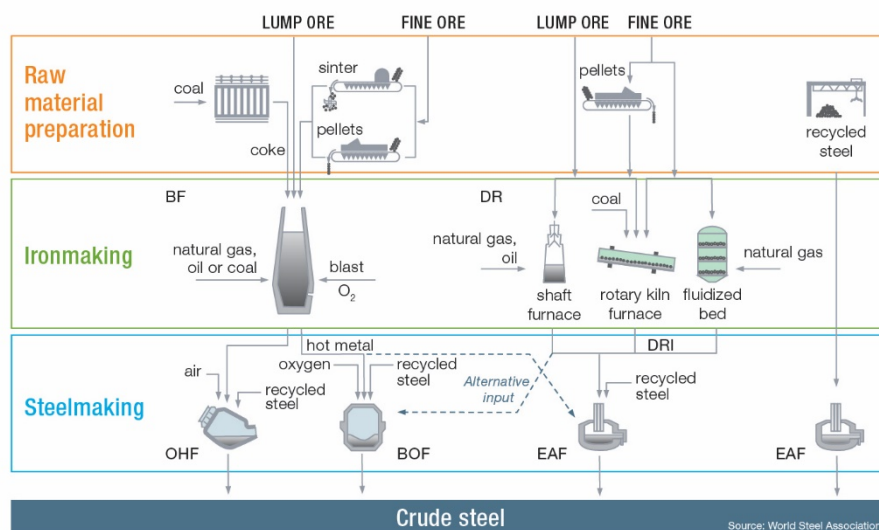

Figure 28 – Different process routes for steel making (World Steel, 2011a).

Recycling steel through electric arc furnace smelting has significantly lower energy consumption (9 to 12.5 GJ/Tonne) compared to primary steel production (19.8 to 41.6 GJ/ton) [90, p. 80], meaning that improving the recycling rate is in the steel industry's interests.

RARE-EARTH METALS IN THE CIRCULAR ECONOMY

The permanent magnets of PM motors contain rare-earth metals such as *neodymium* (typically 31%), *dysprosium* (typically 5.5%), a small quantity of *praseodymium* and small amounts of *terbium* [87]. These metals were all listed as "critical raw materials" by the European Commission in 2017 [92]. This list, which was compiled for the first time in 2011, is based on a criticality assessment that takes arguments such as resource depletion, geopolitical risk and economic importance into account. Substitution and recycling are risk-reducing measures. A similar list is compiled by the US Department of Energy [90].

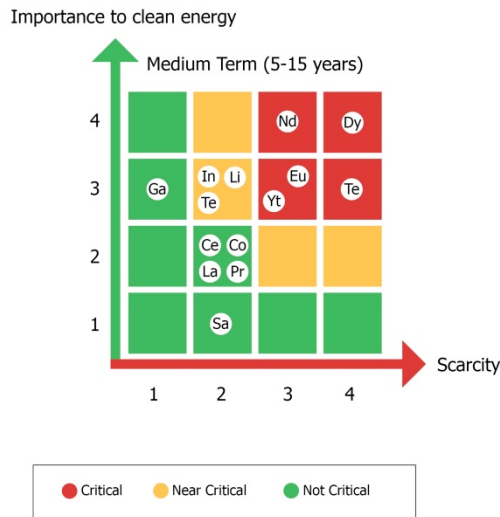

Figure 29 – Critical level in the medium term for some elements; note the presence of Neodymium, Dysprosium and Terbium at upper right (US Department of Energy, 2010) [90, p. 80]

The main issue with the four rare-earth metals mentioned above is the concentration of processing facilities in China, even though they are also mined in other countries, such as Australia and the USA. Ultra-centrifuge and diffusion are required to separate the metals, making the processing plants highly complex. It takes at least five years to set up a new plant. [93] In 2017, 40% of the Neodymium, Dysprosium, Terbium and Praseodymium used in the EU was supplied by China. [92]

The list of critical elements changes over the years. For example, as some of the rare-earth metals are increasingly used, their stock in the urban mine is growing, which could make future recycling profitable if separation is not too challenging. Nevertheless, prudent safeguarding of these materials will play an important role in the sustainable development of our society. A low carbon society cannot be sustainable if it is not resource-efficient [90].

DESIGN FOR RECYCLING

Sustainable metals management requires more than improving recycling rates for some materials. It remains relatively easy to recycle commodity metals such as copper, steel and magnesium. Much more complex is the recycling of products in which small amounts of various metals are present, either next to each other, connected in coatings or claddings, or as alloys. A particular challenge will be the small quantities of different elements that are present in the permanent magnets of PM motors.

To create a true circular economy, we need to change our whole mind-set on the recycling of metals, moving away from a material-centric approach towards a more product-centric approach. In this case, the focus needs to be on the recycling of the entire electric motor at its end-of-life. Only a wide, systemic view on the recycling of motors and all the different elements it contains can deal with the complexity of the industrial and economic parameters involved.

This implies that recycling does not just start with recuperating end-of-life products, but should be considered at the design phase. *Design for Recycling* (DfR) considers the technical and economical effort required to recover as much material as possible at the end-of-life of the product. It requires insight into the complex physics of separating the metals and compounds that are used in motor design. If thermodynamically compatible materials are kept close together in the product design, then metallurgical technology can deal with them during the physical separation for recycling.

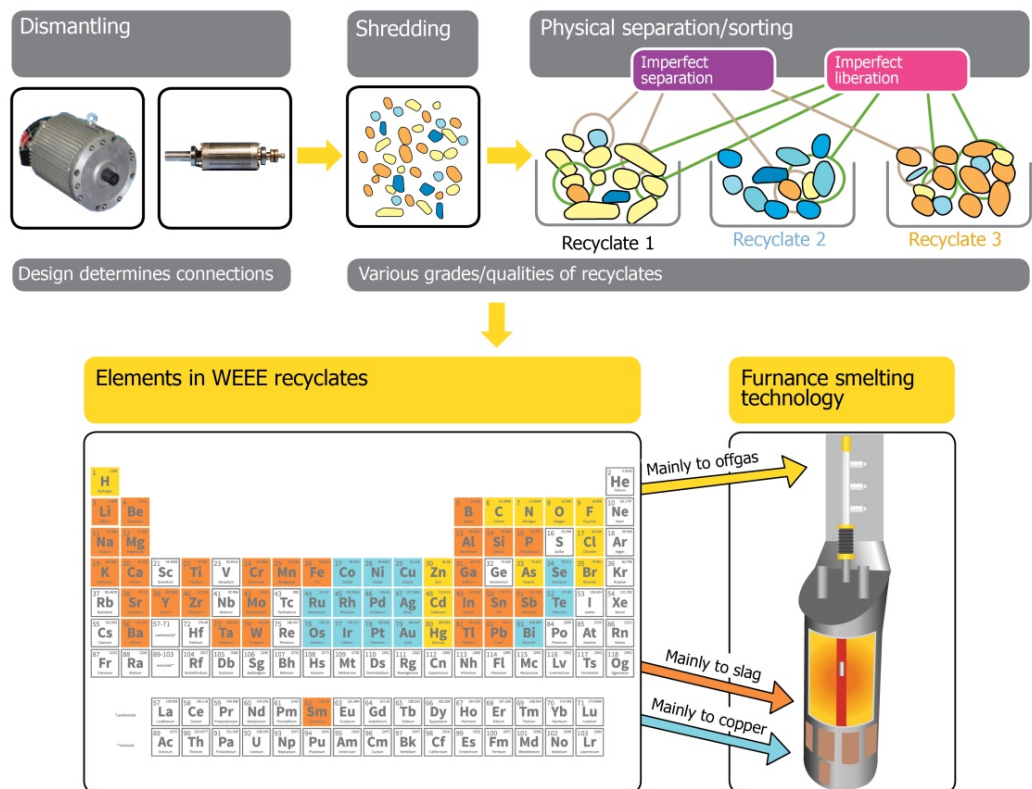

Figure 30 – In a product-centric design, the liberation, separation and quality of the recycled material is fully taken into account, based on the thermodynamic limits of recycling [90, p. 143].

If, for example, certain motor parts are recycled through copper metallurgy, the aluminium present in the mix will be lost. To reduce this loss, design engineers could modify the motor design to facilitate the separation of aluminium and copper during pre-processing. This is known as *design for disassembly*.

One could even claim that the circular economy begins during product R&D. Technological innovation should aim at delivering functionality similar to that of the electric motors we know today, but with materials that are more compatible, easier to recycle, or worth more in the recycling market.

The truly complex challenge to design products for optimal recycling can only be successful with the appropriate supportive infrastructure in place. Tools, such as the Metal-Wheel, are available to provide designers with the necessary information about the recycling outcomes of different designs, enabling a comparative analysis.

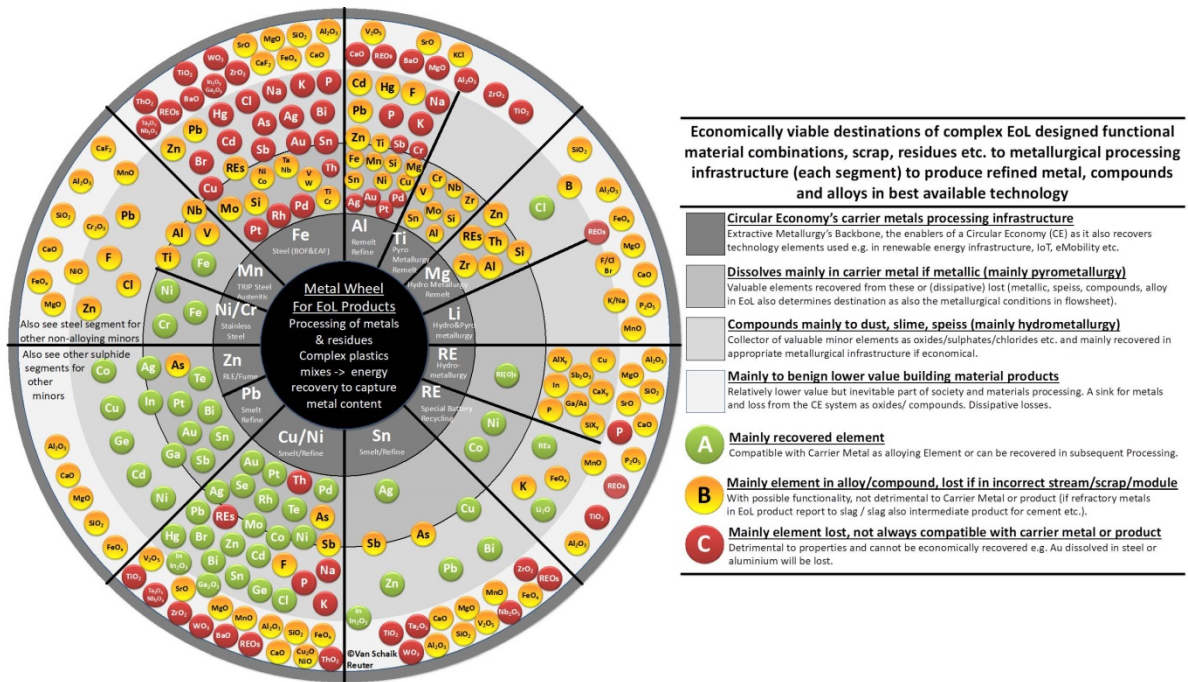

Figure 31 – The Metal-Wheel, based on primary metallurgy. Combined with the thermodynamic limits of recycling, this provides an essential tool for a proper Design for Recycling. Developed by Maras B.V. [94, 95, 96, 97].

Apart from the appropriate tools, the creation of a suitable policy framework that motivates designers is equally important. One element of such a policy could be to provide consumers with neutral and transparent information concerning the recycling friendliness of the product design, for instance through a labelling system. Another possible set of policy actions could be support measures for recycled metals markets [90, p. 146 – 147], for example through public sector procurement and the creation of a centralised product database.

5. POLICY RECOMMENDATIONS AND OTHER CONCLUSIONS

OPTIMISING THE MEPS FOR MOTOR SYSTEMS

Since electric motor systems use more than half of the total electric energy consumption, there has been a long history of policy and regulation efforts in Europe aiming to stimulate their energy efficiency. After a series of voluntary programmes which had mixed success, the first minimum efficiency performance standards (MEPS) for motor systems came into force in 2009. The principle aims of this regulation were carbon emission reductions, improved energy security, and improved economic efficiency. It successfully changed the market from mainly low efficiency (IE1 and IE2) motors to a market with motors of higher energy efficiency (IE3).

The existing set of regulations for motor system efficiency can be made more effective in four ways:

1) Improving MEPS implementation [69]

To harvest its full theoretical annual savings potential of 65.7 TWh and 29.37 million tonnes of CO_{2eq}, implementation must be improved. There is a lack of capacity in the EU to check that electric motors comply with the prevailing standards. The following measures could be effective in improving implementation without the need for independent laboratories systematically verifying all the motors that are sold on the market :

- Stiff penalties for manufacturers of non-compliant motors;
- Random compliance testing by independent laboratories;
- Market self-control: any company, including competitors, can take the initiative to verify motor compliance; if a motor is reported to be non-compliant, this is verified by an independent laboratory.

2) Extending MEPS to other motor categories

The savings potential could be increased by 22.3 TWh/year or 9.97 million tonnes of CO_{2eq}/year by extending the regulation to other motor categories:

- MEPS of IE2 for small single- and three-phase motors (120 W – 750 W);
- MEPS of IE3 of large motors (375 – 1000 kW) of low voltage (< 1000 V) or medium voltage (<6600 V);
- Removing the option to choose an IE2 motor in cases where a VSD is used;
- Removing the exception for brake motors and explosion proof motors.

Moreover, MEPS should be set for systems where the application (such as a compressor, pump or fan) and the electric motor are combined in a single sealed unit.

3) Enhancing MEPS to IE4 for certain motor categories

In the case of medium power motors for which IE3 has already been mandatory since 2015, as well as for large power motors, the minimum efficiency level could be raised to IE4 from 2022 or 2023. Doing so would be economically sound and would save an additional 9.3 TWh and 4.16 million tonnes of CO_{2eq} per year.

4) Extending the focus to the entire motor system

Further carbon emission reductions are possible by focusing **on the entire motor system**, which includes the motor driven unit as well as the application it is driving. Such an extended product approach is difficult to incorporate into workable MEPS with effective market surveillance. A more realistic path is to **actively promote standard IEC 61800-9**, as well as to develop a software tool that can assist in implementing this standard. In addition, motor system energy efficiency can be made more explicit in the international energy management standard (EN 50001) and its implementation guidelines.

A GROWING NUMBER OF MOTORS RESULTING FROM ELECTRIFICATION

Today, a new phase in the energy transition and decarbonisation of Europe is dawning. To decarbonise transport and building HVAC – which until now have mostly been making direct use of fossil fuels – these sectors will be obliged to transition to electrically-driven systems. With this evolution, the number of electric motors in use is expected to rise dramatically (an increase of 6 million units per year in the EU in addition to current sales of 15 million units per year for medium power LV motors). This makes the energy efficiency of these motor systems even more crucial and the impact of energy efficiency regulation even more significant.

Transport electrification can be stimulated through:

- Setting ambitious renewable energy targets for the transport sector in the EU Renewable Energy Directive (RED);
- Setting stringent transport emission targets and a date for an EU-wide ban on fossil fuel vehicles in the longer term;
- Rolling out an extensive network of fast EV chargers (150 kW) along European highways;
- Including targets for slow EV chargers (3.7 kW) in the Energy Performance of Buildings Directive (EPBD);
- Retaining road tax exemptions for EVs as long as their purchase price remains substantially higher than the purchase price of fossil fuel vehicles;
- Focusing Research & Innovation support on the technological development of BEVs, electric buses and electric trucks;
- Returning to rail transport electrification and the development of a high-speed railway network boosted by well-targeted EU policy measures;
- Carefully focusing public procurement by cities and governments to accelerate buses electrification.

The electrification of HVAC in buildings using heat pumps can be stimulated through:

- Setting more stringent MEPS for heating systems in the EcoDesign Directive.
- Actively stimulating EU member states to apply incentives to boost the rate at which the existing building stock is renovated.

MOTOR SYSTEMS WITH FLEXIBLE ENERGY CONSUMPTION

Electricity should not only be used efficiently, its consumption should be shifted where possible to times when its production is abundant, an effort which is gaining ground with the rise of variable renewable energy sources. This means that motor-driven end-use applications will have to participate in demand response (DR) systems. Such systems have still not fully taken off. There is a need for a market model which benefits all parties, while some aspects require further development and harmonisation across the EU:

- A standardised two-way communication channel between grid operators and end-users should be introduced. Based on this, the technology of load interruptibility can be developed further;
- The reserve and balancing markets (FCR and aFRR) should be opened up to industrial electricity consumers and to aggregating companies, with a guarantee of fair technical conditions;
- A more direct and less complicated way to participate wholesale electricity markets (day-ahead and intraday) should be available to SMEs and independent aggregators;
- Network operators should manage the network in an active and open manner, communicating openly about the network constraints they are facing, and giving industrial consumers the opportunity to participate in local network services;
- A more accurate demand forecasting system which includes all substantial contributions to load reductions should be put in place;

- Net-metering policies which serve to reduce the economic viability of renewable energy self-generation – as exist in some EU countries – should be abandoned.

MOTORS IN THE CIRCULAR ECONOMY

The increased numbers of motor systems will result in substantially increased demand for the materials used to manufacture these motor drives. This can only be sustainable in the longer term if these motors have the potential to function in a circular economy. *Design for Recycling* (DfR) encompasses the technical and economical effort required to recuperate as much material as possible at the end-of-life of a product. DfR for electric motors and other products can be stimulated by:

- Providing the buyers of electric motors with information on its recyclability, for example through a DfR label;
- Setting DfR as a criterion in public procurement;
- Stimulating the market for recycled metals through centralised metals databases;
- Focusing Research & Innovation support on the development of rare-earth-free EV drives.

ANNEX – THE ESTIMATED MARKET INCREASE IN MOTOR SYSTEMS

INCREASE IN THE SHARE OF ELECTRICITY CONSUMED BY MOTORS

Electricity represented 17% of total energy use in the EU-28 in 2014 [98]. Electric motor systems use approximately 53% of the global electric energy consumption [2 p. 40], amounting to 10,700 TWh in 2016. According to a study by EMSA [99], these figures are expected to rise significantly.

By the year 2040:

- 30% of total energy use will be electrical
- 60% of this electricity will be used by electric motors

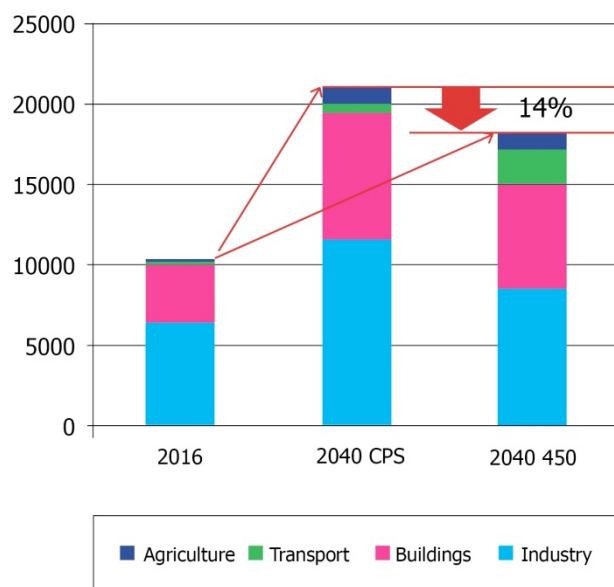

Figure 32 – Expected rise in the global electricity consumption of motor systems (TWh) and the energy savings potential through electric motor efficiency.

Figure 32 shows the potential influence of the energy efficiency measures described in Chapter 2. The total electricity consumption of motor systems is expected to climb from 10,700 TWh to 21,000 TWh by 2040. As a result of these energy efficiency measures, the motor electricity consumption in 2040 would be limited to around 18,000 TWh.

In the longer term, with the energy transition persisting, the energy consumption of electric motors is expected to rise even further. In his book about a renewable energy future, David JC MacKay outlines five possible future scenarios for the UK's energy future [100 p. 212]. In every scenario, non-electrical renewables add up to a maximum of 28.5% of total energy use, because second generation biomass production would otherwise come into conflict with other essential land uses, such as agriculture and nature preservation. Only the successful development of a third generation of biomass that is less dependent on land use could break this threshold. Alternatively, at least 60% of all energy used would have to be electrical renewable systems. With electric motors consuming 60% of all electricity, the energy use of electric motors would rise to 36% of total energy use, or approximately 40,000 TWh.

INCREASE IN THE NUMBER OF MOTORS IN USE

The increase in the number of motor systems will largely happen through the development of electric vehicles and heat pumps. This allows us to make an initial rough estimate of the numbers, limiting the calculation to these two markets.

According to a study by BNEF [101], global electric vehicle sales will surpass internal combustion engine sales by 2038.

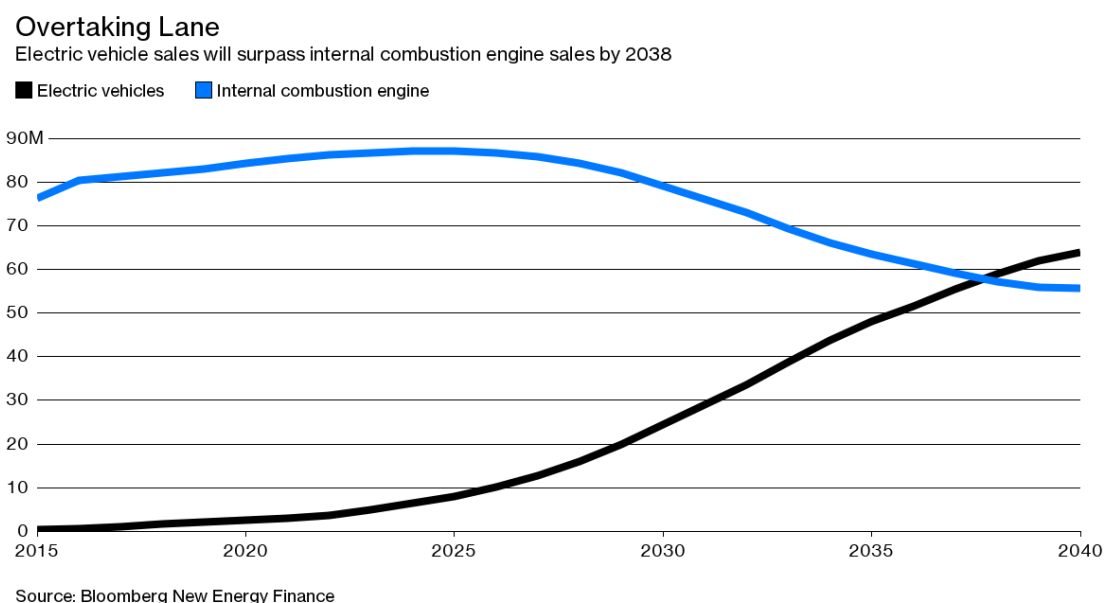

Figure 33 – Expected evolution of the worldwide sales figures of cars with an internal combustion engine and of electric vehicles (BNEF [101]).

If this sales prediction is correct, approximately one in three of the vehicle fleet will be electric by 2040. Currently, there are around 255 million cars in the EU-28 [102]. The growth rate for passenger cars has been slightly below 1% in recent years (namely 6% between 2005 and 2012 [102]). If we suppose that this growth rate will continue, the EU passenger fleet would rise to 312 million cars by 2040. If a third of these are EVs, as predicted by Bloomberg, this means there would be 104 million EVs on the road by that date. By 2016, there were just 2 million electric cars on European roads [103]. This means that **the number of electric cars (and their electric motors) on the road will increase by about 100 million units between 2016 and 2040**. This is a rough estimate, but it goes to show the massive scale of the transition.

A similar calculation can be made for residential heating systems. According to Road Map 2050 by the European Commission [104], half of all residential HVAC systems will have to be renewable by 2040. In a UK study, the future share of heat pumps in renewable HVAC is estimated at 50% [105]. Basing our calculations on these targets and estimates, 25% of the 220 million dwellings in the EU [56] will be equipped with a heat pump by 2040. Consequently, the number of heat pumps in the EU-28 by 2040 will be about 55 million. Currently, nearly 9 million heat pumps are in use (2016) [106]. As a consequence, to meet the European Commission targets, **the number of heat pumps in the EU28 will have to increase by 46 million units between 2016 and 2040**. And this could still be regarded as a conservative estimate. In Denmark, the installation of oil or gas fired boilers in new buildings has been prohibited since 1 January 2013 and since 1 January 2016, new installations of oil-fired boiler are banned from existing buildings in areas where district

heating or natural gas is available. If the EU decided to follow this example in the next few years, the heat pump market could grow even faster than our prediction.

Combining both figures brings us to an additional 146 million electric motors coming into use between 2016 and 2040, or **6 million motors per year**.

This will come in addition to the current annual medium-power (0.75 - 1000 kW) LV motor sales in the EU of 15 million units (based on 2016 figures, including motors in industry, infrastructure and large buildings, as well as motors with a power above 0.75 kW for residential applications, excluding traction motors [107]).

The above estimations lead to a **40% increase of the annual motor sales** [108]. The annual growth rate of the number of motors in use would increase along from 1% to 1.4%.

REFERENCES

- [1] Eurostat, [Gross inland consumption of energy](#) and [Net electricity generation](#)
- [2] P. Waide and C. Brunner, [Energy Efficiency Policy Opportunities for Electric Motor Driven Systems](#), IEA 2011
- [3] Alberto Moro, Laura Lonza, Elsevier and ScienceDirect, [Electricity carbon intensity in European Member States: Impacts on GHG emissions of electric vehicles](#), 27 July 2017
- [4] Eurelectric, [The European Power Sector in Transition](#)
- [5] Ecofys, [Flexibility Options in Electricity Systems](#), March 2014
- [6] [European Environment Agency](#)
- [7] European Commission, [COMMISSION STAFF WORKING DOCUMENT / IMPACT ASSESSMENT / Accompanying the document "Proposal for a Directive of the European Parliament and of the Council amending Directive 2012/27/EU on Energy Efficiency"](#), Brussels, 30.11.2016
- [8] IEA (International Energy Agency) and UIC (International Union of Railways), [Railway Handbook 2017](#)
- [9] European Commission, JRC Technical Report, [Well-to-wheels / Summary of WTW Energy and GHG balances](#)
- [10] The World Bank, [The cost of air pollution: strengthening the economic case for action](#), September 2016
- [11] Aria Technologies, Fanny Velay-Lasry, [Pourquoi les Véhicules Electrique son tune solution de mobilité durable?](#)
- [12] Elsevier Environmental Research, Volume 137, February 2015, pages 136-140, [Health impact assessment of traffic noise in Madrid \(Spain\)](#)
- [13] Eurostat, [Oil and petroleum products – a statistical overview](#), June 2017
- [14] Cambridge Econometrics, [Fueling Europe's Future](#)
- [15] Maria Hernandez, Maarten Messagie, Michele De Gennaro, Joeri Van Mierlo, [Resource depletion in an electric vehicle powertrain using different LCA impact methods](#), in Resources, Conservation and Recycling magazine n° 120 (2017) by Elsevier
- [16] European Commission, Research and Innovation submission form, [Rare Earth Free e-Drives featuring low cost manufacturing](#)
- [17] European Training Network for the Design and Recycling of Rare-Earth Permanent Magnet Motors and Generators in Hybrid and Full Electric Vehicles (DEMETER), [Let's discuss motors in electric vehicles \(continued...\)](#), September 2016
- [18] ELECTRICAL Engineering, [Why does a Tesla car use an AC motor instead of a DC one?](#), July 2013
- [19] James D. Widmer, Richard Martin, Mohammed Kimiabeigi, Newcastle University (UK), [Electric vehicle traction motors without rare earth magnets](#), Elsevier, March 2015
- [20] Free University of Brussels (VUB), SYRNEMO, [Synchronous Reluctance Motors for Electric Vehicles](#)
- [21] International Energy Agency (IEA), [Global EV Outlook 2016](#)
- [22] ResearchGate, [Development of the Primary Energy Factor of Electricity Generation in the EU-28 from 2010-2013](#), March 2015
- [23] European Environment Agency, [Electric vehicles and the energy sector - impacts on Europe's future emissions](#), September 2016
- [24] International Energy Agency (IEA), [Global EV Outlook 2017](#)
- [25] Cambridge Econometrics, [Fueling Europe's Future](#)
- [26] European Commission, [Urban Access Regulations in Europe](#)

-
- [27] European Commission, [Driving and parking patterns of European Car Drivers – a mobility survey](#)
- [28] [Green e-Motion project](#)
- [29] Eurelectric, [European Commission legislative proposal to amend the Energy Performance of Buildings Directive / An Eurelectric position paper](#), April 2017
- [30] Clean Technica, [Amsterdam's Electric Vehicle Leadership](#), November 2017
- [31] Auto's CheatSheet, [10 Electric Vehicles With the Best Range in 2017](#), December 2017
- [32] International Railway Journal (IRJ), [Repower or Replace: The route to cleaner diesel](#), December 2013
- [33] European Commission, [Help for rail industry on cutting pollutants from diesel engines](#), March 2015
- [34] Eurelectric, [The electrification of heavy duty vehicles](#), September 2017
- [35] Vox, [Tesla's electric semi-truck: Elon Musk unveils his new freight vehicle](#), November 2017
- [36] Business Insider, Danielle Muoio, [Mercedes built an electric truck that could rival Tesla – here's everything you need to know](#), 1 July 2017
- [37] Transport & Environment, [Will electric trucks take charge?](#), September 2017
- [38] Orhan B Alankus, *Technology Forecast for Electrical Vehicle Battery Technology and Future Electric Vehicle Market Estimation*, Advances in Automobile Engineering, OMICS International Volume 6 • Issue 2, 2017, DOI: 10.4172/2167-7670.1000164
- [39] Techspot, [Sweden becomes first nation to open electric highway that powers trucks using overhead lines](#), June 2016
- [40] European Environment Agency, [Size of the vehicle fleet](#), December 2017
- [41] Jeremy Hodges, Bloomberg.com, [Electric Buses Are Hurting the Oil Industry](#), April 2018
- [42] C40 Cities, [Mayors of 12 Pioneering Cities Commit to Create Green and Healthy Streets](#), Paris, October 2017
- [43] Judah Aber, Columbia University, [Electric Bus Analysis for New York City Transit](#), May 2016
- [44] [The Electric Boat Association](#)
- [45] Mircea Popesco, Motor Design Limited, *Solutions and Challenges - Electric Machines for Aerospace and Automotive Applications*, presented at the ECI and University of Aquila Motor Workshop, Rome, March 2018
- [46] European Commission, Energy Union, [Good practice in energy efficiency / For a sustainable, safer and more competitive Europe](#), 2017
- [47] Ecofys, [Heat Pump Implementation Scenarios until 2030](#), January 2014
- [48] UK Houses of Parliament, Postnote Number 523, [Carbon Footprint of Power Generation](#), May 2016
- [49] Leonardo Energy Application Note, Keeran Jogdoyal, [Heat Pumps for Larger Buildings](#), April 2013
- [50] Energy.gov, [Heat Pump Systems](#)
- [51] REHVA, Federation of European Heating, Ventilation and Air Conditioning Associations, [Capacity control of heat pumps](#), October 2010
- [52] European Heat Pump Association, [Data Sources](#), 2016
- [53] [Commission Regulation \(EU\) No 813/2013](#)
- [54] BPIE, [nZEB definitions across Europe](#), April 2015
- [55] The Hague Centre for Strategic Studies & TNO, [Sustainable \(Re\)Construction / The Potential of the Renovation Market](#), Annotated Briefing, December 2013

-
- [56] OTB Research Institute for the Built Environment, [Housing statistics in the European Union](#), September 2010
- [57] European Commission > Policies, information and services > Energy > Energy Efficiency > [Buildings](#)
- [58] European Heat Pump Association (EHPA), European Copper Institute, *Heat Pumps / A key integration technology to decarbonise heating and cooling*
- [59] Fraunhofer ISI, Anke Esser, Frank Sensfuss, [Evaluation of primary energy factor calculation options for electricity](#), May 2016
- [60] Steve Dickerson, [5 Reasons to Switch from Pneumatic to Electromechanical Actuators](#), April 2014
- [61] Exlar Corporation, [Benefits of Electric Cylinders over Hydraulic Cylinders](#), Technical Reference Note
- [62] International Energy Agency (IEA), 4E, [Energy efficiency roadmap for electric motors and motor systems](#), November 2015
- [63] ACEEE Summer Study on Energy Efficiency in Industry; R. Werle, C.U. Brunner, R. Tieben, Impact Energy Inc.; [Swiss motor efficiency program EASY: results 2010 - 2014](#); Buffalo, NY, USA, 2015
- [64] GAMBICA/CAPIEL, Andrew Evans, *An energy efficient, system based approach to motor control*, 2017
- [65] ISR University of Coimbra, Anibal T. de Almeida, [“Electric Motors and Variable Speed Drives Efficiency – Adjusting MEPS to Technology Developments”](#), Motor Summit Zurich, 11/12 October 2016
- [66] European Commission, [Guidelines accompanying Commission Regulations \(EC\) No 640/2009 of 22 July 2009 \(implementing directive 2005/32/EC with regards to eco-design requirements for electric motors\) and No 4/2014 of 6 January 2014 amending regulation \(EC\) no 640/2009](#), December 2014
- [67] Anibal T. de Almeida, Joao Fong, Hugh Falkner, Paolo Bertoldi, [Policy options to promote energy efficient electric motors and drives in the EU](#), RSER Journal 74, 2017
- [68] Dr Ruben Kubiak, [The EU’s Ecodesign Requirements for Motors, Fans, Pumps and Circulators](#), Motor Summit 2016, Zurich
- [69] Jürgen Sander, CEMEP, [Efficient Motor Policy for Europe / View from CEMEP](#), Motor Summit 2016, Zürich, Switzerland
- [70] Norbert Hanigovszky, Danfoss, [A new international standard for energy efficiency – IEC61800-9](#), June 2017
- [71] European Commission > Energy > Topics > Energy Efficiency > Energy efficient products > [Circulators](#)
- [72] United Nations Industrial Development Organization (UNIDO), Standardization Administration of the People’s Republic of China (SAC), Working Group Meeting, *Towards an ISO Management System Standard for Energy*, 9-11 April 2008, Beijing, China
- [73] International Organization for Standardization (ISO), *ISO 50001, Energy Management System – Requirements with guidance for use*, ISO Central Secretary, Switzerland, 2011
- [74] McKane, A., Williams, R., Perry, W., Li, T.: [Setting the Standard for Industrial Energy Efficiency](#), on the International Conference on Energy Efficiency in Motor Driven Systems (pp. 1–10), Beijing, 2007
- [75] [Commission Regulation \(EU\) No 813/2013](#)
- [76] Leonardo Energy Application Note, [Load Management of Industrial Systems](#), December 2016
- [77] Leonardo Energy Application Note, [Wind Powered Industrial Processes](#), September 2016
- [78] IndustRE, VITO/EnergyVille, *Flexible Industrial Demand Assessment / Case Studies Summary*
- [79] IEA - DSM Energy Efficiency, [Task 25 – Business models for a more effective market uptake of DSM Energy services](#), November 2015

-
- [80] IndustRE project, *Business models for large industrial electricity users and necessary policy recommendations*, Brussels, January 2018
- [81] [IndustRE project](#), *Using the flexibility potential in energy intensive industries to facilitate further grid integration of variable renewable energy sources*
- [82] Ministry of Energy and Utilities, [NSW Code of Practice, Demand Management for Electricity Distributors](#), May 2001
- [83] Damien Giurco, Anna Littleboy, Thomas Boyle, Julian Fyfe, and Stuart White, Circular Economy: [Questions for Responsible Minerals, Additive Manufacturing and Recycling of Metals](#), MDPI Open Access Resources, 2014
- [84] European Commission, [Report from the Commission to the European Parliament, the Council, the European Economic and Social Committee and the Committee of the Regions on the implementation of the Circular Economy Action Plan](#), January 2017
- [85] AEMT (The Association of Electrical & Mechanical Trades), Hugh Falkner, [Dr Hugh Falkner looks at The Circular Economy and the Motor Repair Industry](#), December 2017.
- [86] University of L'Aquila, F. Parasiliti, M. Villani, [New induction motor designs with Aluminum and Copper rotor specially developed to reach the IE3 efficiency level](#)
- [87] EWI, [Rare Earth Materials / Important Industrial Applications and Uses](#), February 2011
- [88] International Copper Association, [Copper Recycling](#), 2017
- [89] John Atherton, [Life Cycle Management / Declaration by the Metals Industry on Recycling Principles](#), ICMM, Int J LCA 2006
- [90] United Nations Environment Programme (UNEP), International Resource Panel, [Metal Recycling / Opportunities, limits, infrastructure](#), 2013
- [91] Eurofer / European Steel Association website, [Closed Loops: sustainable from the start](#)
- [92] European Commission, [Critical Raw Materials](#)
- [93] Alex Van den Bossche, Ghent University, *Electric Motors: Long-term Trends and their Impact on the Market*, presented at the ECI Conference "Trends in the Electric Motor and Generator Market to 2030", April 2016
- [94] E. Verhoef, G. Dijkema, M.A. Reuter (2004), *Process knowledge, system dynamics and metal ecology*, Journal of Industrial Ecology, 8(1-2), 23-43
- [95] M.A. Reuter, A. van Schaik (2012), *Opportunities and limits of WEEE Recycling - Recommendations to product design from a recyclers perspective*, in proceedings of Electronics Goes Green 2012+ (EGG), 2012, 8 p.
- [96] A. van Schaik, M.A. Reuter, *Material-Centric (Aluminum and Copper) and Product-Centric (Cars, WEEE, TV, Lamps, Batteries, Catalysts) Recycling and DfR Rules*, in: Handbook of Recycling (E. Worrel and M.A. Reuter) (<http://dx.doi.org/10.1016/B978-0-12-396459-5.00022-2>), pp. 307-378
- [97] M.A. Reuter, A. van Schaik, M. Ballester (2018), *Limits of the Circular Economy: Fairphone Modular Design Pushing the Limits*, World of Metallurgy – ERZMETALL 71(2), pp. 68-79.
- [98] Eurostat, [Gross inland consumption of energy](#) and [Net electricity generation](#)
- [99] Maarten van Werkhoven, EMSA, *Electric Motor Systems*, presented at the ECI Motor Workshop, Brussels, March 2017
- [100] David JC MacKay, [Sustainable Energy – without the hot air](#), UIT Cambridge 2009
- [101] Bloomberg, Jess Shankleman, [The Electric Car Revolution is Accelerating](#), July 2017
- [102] Eurostat, [Passenger Cars in the EU](#), April 2017

-
- [103] Wikipedia, [Electric car use by country](#)
- [104] European Commission, [Energy Roadmap 2050](#), 2012
- [105] GreenMatch, [The Future of Heat Pumps in the UK](#), March 2016
- [106] [European Heat Pump Association](#)
- [107] Anibal T. de Almeida, João Fong, *Impact of IE4 regulation for copper*, February 2018
- [108] MarketsandMarkets, [Electric Motor Sales Market / Global Forecast till 2021](#), October 2016